



# Application Form

## 2006 System Showcase

Radiant Panel Association  
1399 S. Garfield Ave., Loveland, CO 80537

Phone: (970) 613-0100  
Fax: (970) 613-0098

Response ID RE604

Date Posted 6/6/2006

### Step 1 CATEGORY

Retrofit - adapting radiant to an existing system or structure

### Step 2 SUBMITTED BY

COMPANY:  
CONTACT:  
PHONE:  
ADDRESS:

EMAIL:

PROJECT OWNER:

PHONE:

### Step 3 PROJECT INFORMATION

PROJECT NAME: [Cobblestone Winery](#)  
YEAR COMPLETED: [2005](#)

LOCATION: [Romulus, NY](#)  
SQ FT LIVING AREA: [1417](#)

STRUCTURE AGE: [15 years](#) SPACE HEATED/COOLED BY RADIANT: [1417](#) sq ft  
LEVELS/STORIES: [one](#)

STRUCTURE CONSTRUCTION: [wood frame](#) Other

STRUCTURE USE: [other](#) Other [Winery/Tasting Room](#)

PROJECT TYPE:

Heating  Cooling  Snow Melting Other Type

RADIANT PANEL LOCATION:

Floor  wall  Ceiling Other Location

Radiant Zones: # [3](#)

ADDITIONAL FUNCTIONS:

Fan Coil  Domestic HW  Hot Tub  Pool

Convectors Other Functions

UTILITY:

Electric  Natural gas  Propane  Oil

Solar Other Utility

HEAT SOURCE:

Resistance  Boiler  Heat Pump  Water Heater

Furnace Other Heat Source

**Step 4 PANEL DESCRIPTION****Floor Panels**

## TUBE OR ELEMENT:

- ` Cable     ` Film     ` PEX tube     ` PB tube     ` Rubber     ` PE/Metal  
 ` P E     ` Copper    Other Tube/Element PEX-AL-PEX

## PANEL CONSTRUCTION:

- ` Concrete slab on grade     ` Concrete slab below grade     ` Sand below concrete slab  
 ` Gypsum on concrete     ` Gypsum on wood subfloor     ` Concrete/wood subfloor  
 ` Wood sleepers     ` Under wood subfloor     ` Suspended in joist bay  
 ` Aluminum plates     ` Reflective barrier     ` Premanufactured panels

## PANEL COVERING:

- ` Carpet glued     ` Carpet & pad     ` Hardwood     ` Softwood  
 ` Ceramic Tile     ` Stone     ` Brick     ` Bare  
 Other Panel Covering

## OTHER PANEL DETAILS:

**Tube Size:** 1/2 inch    **Cable Size:**                  watts/ft    **Spacing:** 6    to    12    in o/c (range)

**Wall Panels**

- ` Cast iron                                   ` Welded steel                                   ` Extruded aluminum  
 ` Embedded tube/cable     ` Premanufactured electric  
 Other Wall

**Ceiling Panels**

- ` Embedded tube/cable     ` Premanufactured electric     ` Premanufactured hydronic

**Snow Melt Panels**

## SNOW MELT CONSTRUCTION:

- ` Embedded tube                                   ` Embedded cable  
 ` Asphalt     ` Concrete     ` Pavers

## SNOW AND ICE MELTING:

- ` Always clear and dry     ` Melt and run off                                   ` Melt within an hour of snowfall

**Step 5 CONTROLS**

INDOOR SENSING:

**3** Air sensing thermostats **1** Panel sensors **2** Remote Air Sensor

OUTDOOR SENSING:

**Reset heat source high limits** **Secondary loop temp controls**

PANEL TEMPERATURE CONTROL:

<b>1</b> 3-way mixing valves	<b>4-way mixing valves</b>	<b>Injection valves</b>
<b>Injection Pumps</b>	<b>Heat exchangers</b>	<b>On-off valves</b>
<b>1</b> On-off pumps <b>1</b>	<b>On-off heat source</b> <b>1</b>	<b>Digital Temperature sensor</b>

ROOM CONTROL:

<b>3</b> Zone valves	<b>Manifold telestats</b>	<b>Pumping zones</b>
<b>Thermostatic valves</b> <b>1</b>	<b>Relays (electric system)</b> <b>1</b>	<b>Circulator control module</b>

**Step 6 ADDITIONAL DESCRIPTION**

This project was a retrofit of an existing building that was used for storage and fruit packaging.

The fruit packaging area was converted to a wine tasting room with the addition of new restrooms and a future office. The fruit packaging room had an existing slab that was removed. A new slab was installed with the barrier slab insulation, wire mesh, and kitect 1/2 pex-al-pex.

To help control the system from overshooting a tekmar programmable thermostat with slab sensor was installed in the tasting room zone. To keep the restrooms as one zone, a tekmar thermostat was installed in the women's bath with a remote air sensor in the men's room. The office zone had one tekmar programmable thermostat to maintain temperature.

There was an existing conventional boiler producing 180 degree water that was feeding two zones. The first zone was an indirect hot water heater and the second a fan coil in the storage room. We cut into the existing primary loop after the fan coils where the water temperature was the lowest. The system uses a three way thermostatic mixing valve to provide 105-110 degree water to the radiant heat system. We used the Azel digital temperature gauge to monitor the pre-mix temperatures. The system was simple but very effective.

**Step 7 DESCRIPTIVE PROJECT PHOTO**

Photo format print

Sending mail



**Step 8 SUPPORTING PHOTOGRAPHS**

Photo format jpeg

Sending disc











Cobblestone Winery  
Electrical Schematic  
Radiant Heat Addition

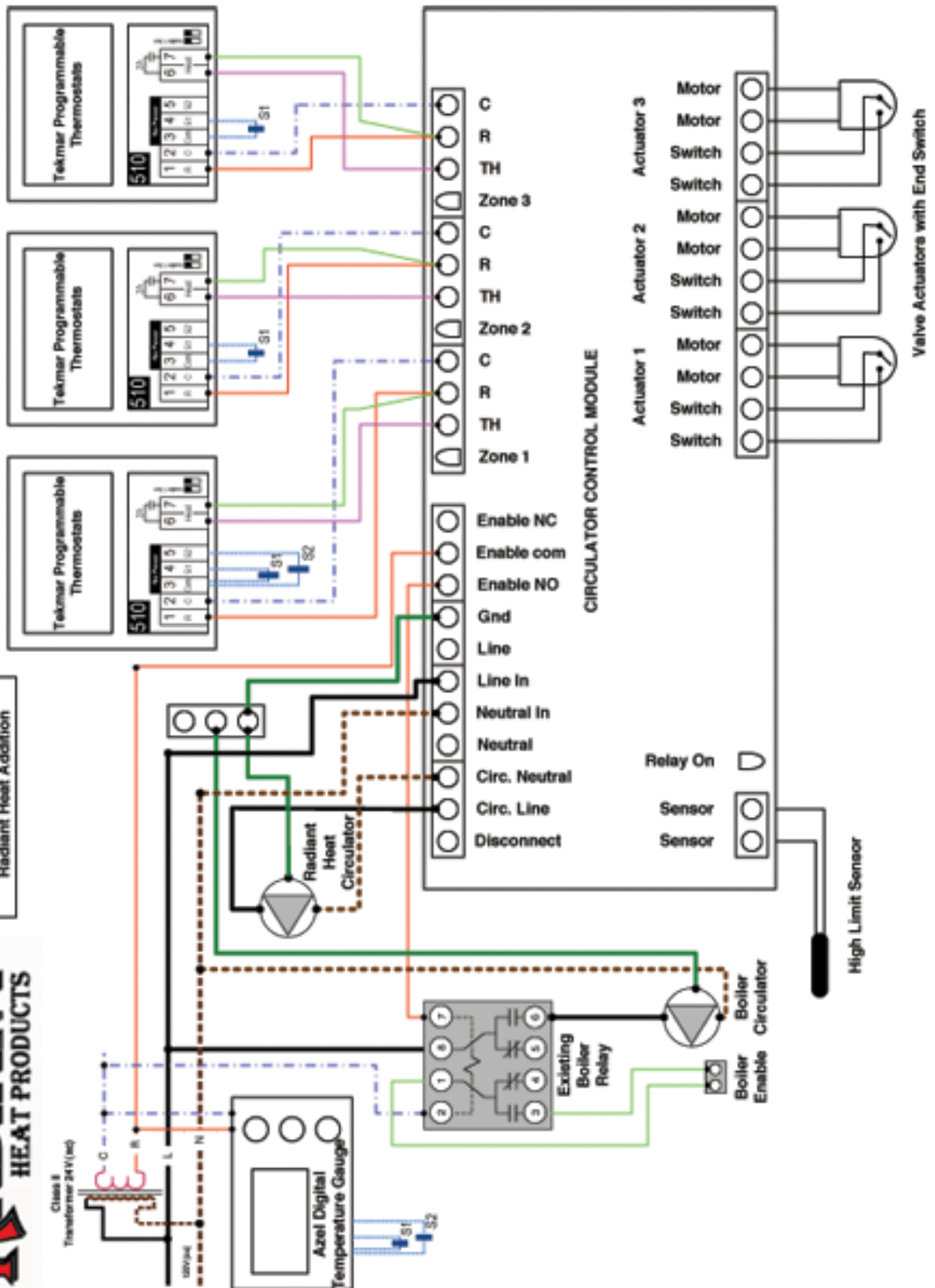

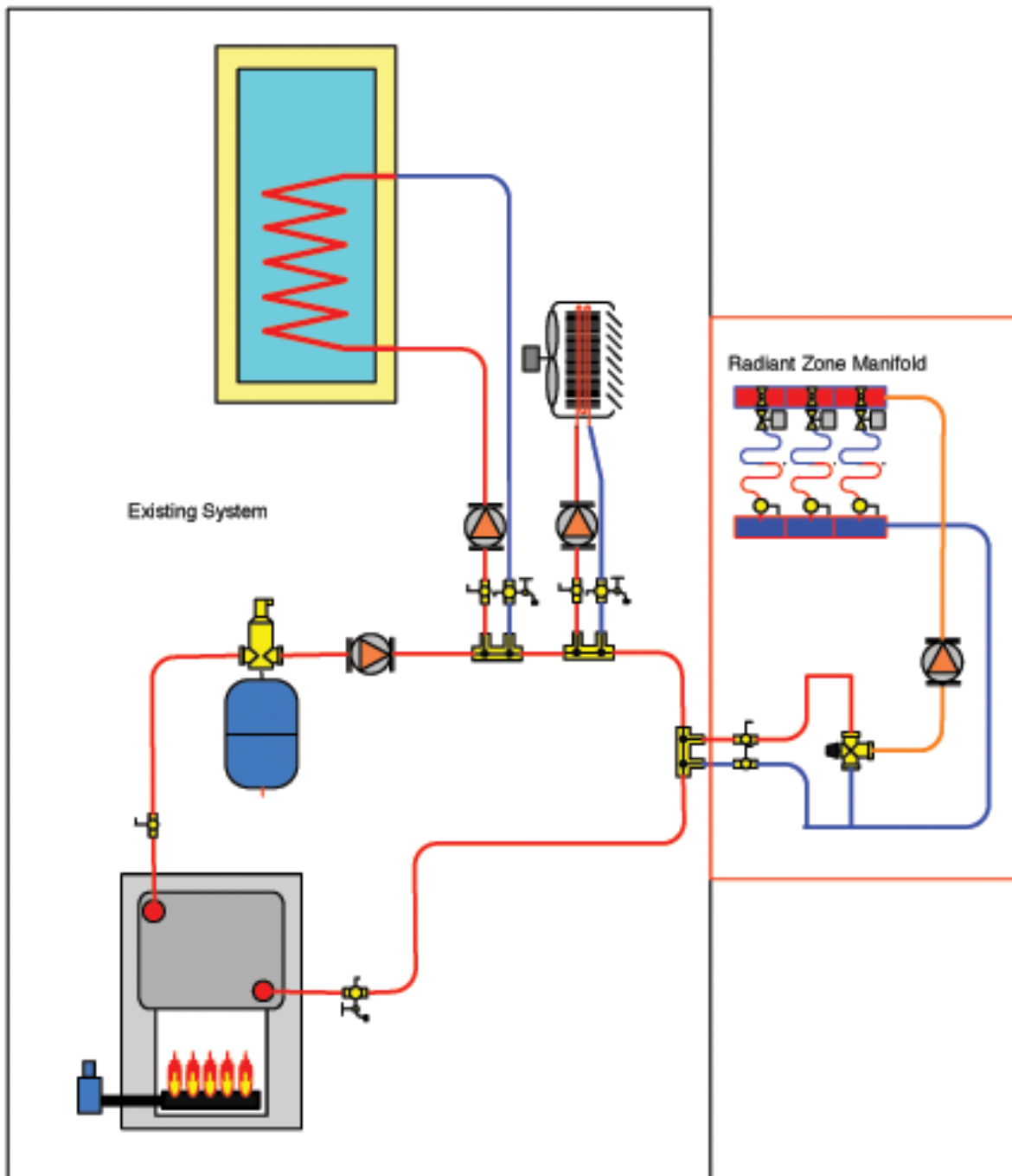

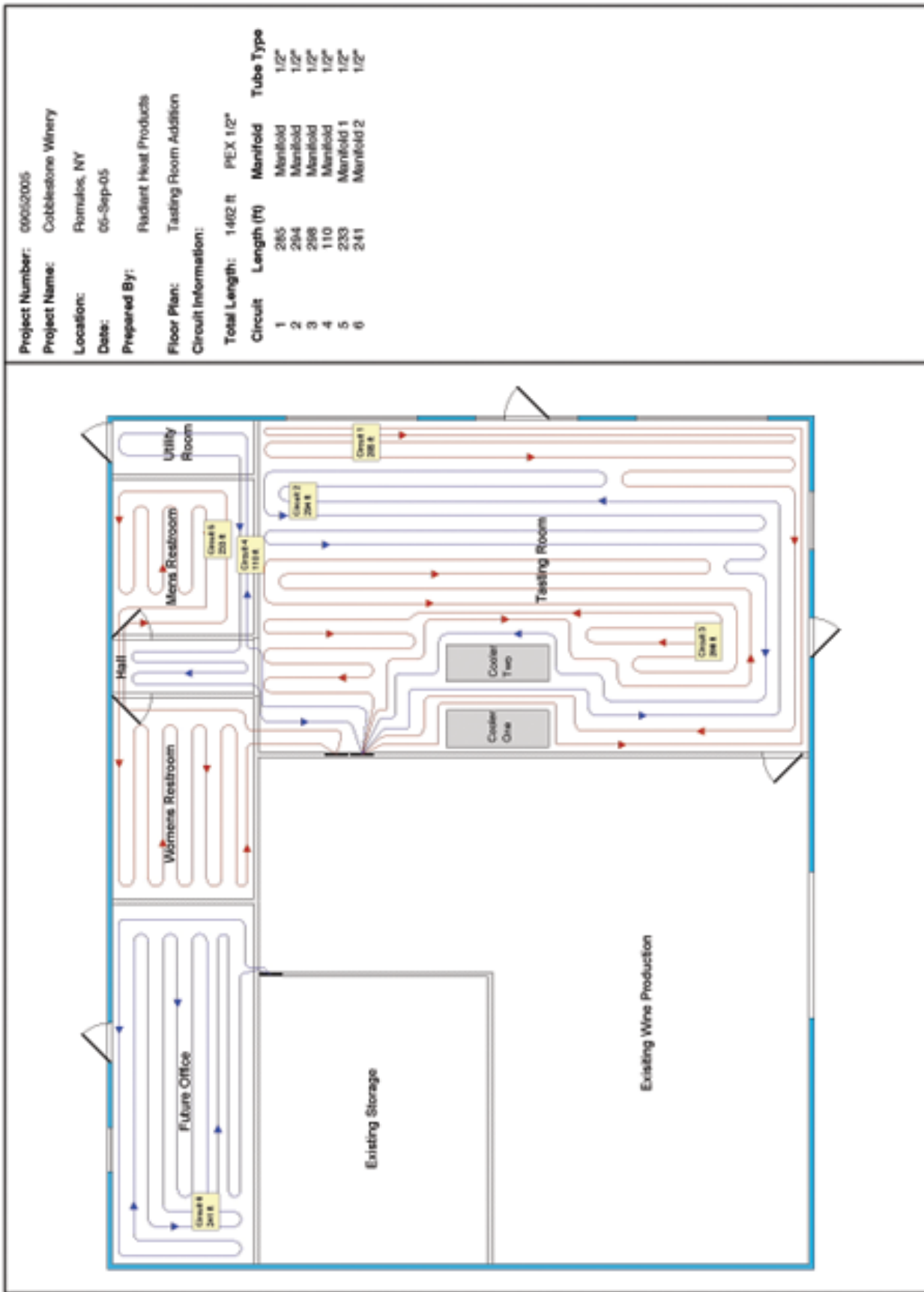

Project Number: 09052005  
 Project Name: Cobblestone Winery  
 Location: Romulus, NY  
 Date: 05-Sep-05  
 Prepared By: Radiant Heat Products  
 Floor Plan: Tasting Room Addition  
 Circuit Information:

Project Number: 09052005  
 Floorplan: Tasting Room Addition (Not To Scale)

Note: Details of the tubing bend radius have been simplified for clarity. Consult tubing manufacturer for specific bend radius recommendations.  
 Created using LoopCAD Standard Edition (Version 1.50 (Revision 1))

