

Installing, Operating & Maintaining **MUNCHKIN™ VWH HIGH EFFICIENCY** **HOT WATER SUPPLY BOILER**

⚠ WARNING

If the information in this manual is not followed exactly, a fire or explosion may result causing property damage, personal injury or loss of life.

Do not store or use gasoline or other flammable vapors and liquids in the vicinity of this or any other appliance.

WHAT TO DO IF YOU SMELL GAS

- Do not try to light any appliance.
- Do not touch any electrical switch: do not use any phone in your building.
- Immediately call your gas supplier from a neighbor's phone. Follow the gas supplier's instructions.
- If you cannot reach your gas supplier, call the fire department. Installation and service must be performed by a qualified installer, service agency or the gas supplier.



⚠ WARNING

This manual must only be used by a qualified heating installer / service technician. Failure to comply could result in severe personal injury, death or substantial property damage. It is also important to keep these Instructions with the appliance.

USING THIS MANUAL

SPECIAL ATTENTION BOXES

Throughout this manual you will see these special attention boxes similar to this one, which are intended to supplement the instructions and make special notice of potential hazards. These categories mean, in the judgement of Heat Transfer Products, Inc.:

DANGER

DANGER indicates an imminently hazardous situation which, if not avoided, will result in death or serious injury.

WARNING

WARNING indicates a potentially hazardous situation which, if not avoided, could result in death or serious injury.

CAUTION

CAUTION Indicates a potentially hazardous situation which, if not avoided, may result in minor or moderate injury.

CAUTION

CAUTION used without the safety alert symbol indicates a potentially hazardous situation which, if not avoided, may result in property damage.

WARNINGS

- THIS UNIT IS FOR CATEGORY IV VENTING - 2 PIPE ONLY. THIS IS A SEALED COMBUSTION APPLIANCE.
- THIS HEATER INSTALLATION MUST CONFORM TO THE LATEST EDITION OF THE "NATIONAL FUEL GAS CODE" ANSI Z223.1 NEPA 54 AND OR CAN/CGA B149 INSTALLATION CODES. STATE AND LOCAL CODES MIGHT ALSO APPLY TO INSTALLATION.
- WHERE REQUIRED BY THE AUTHORITY HAVING JURISDICTION, THE INSTALLATION MUST CONFORM TO THE STANDARDS FOR CONTROLS AND SAFETY DEVICES FOR AUTOMATICALLY FIRED HEATERS, ANSI/ASME HEATER AND PRESSURE VESSEL CODE, Section IV, ALONG WITH CSD1.
- THE HEATER, GAS PIPING, WATER PIPING, VENTING AND ELECTRICAL MUST BE INSTALLED BY TRAINED & QUALIFIED PERSONNEL FAMILIAR WITH INSTALLATION PRACTICES, LOCAL CODE, LICENSING REQUIREMENTS.
- IF THE INFORMATION IN THESE INSTRUCTIONS ARE NOT FOLLOWED EXACTLY, A FIRE OR EXPLOSION MAY RESULT; CAUSING PROPERTY DAMAGE, PERSONAL INJURY, OR DEATH.
- DO NOT STORE OR USE GASOLINE OR OTHER FLAMMABLE VAPORS AND LIQUIDS IN THE VICINITY OF THIS OR ANY OTHER APPLIANCE;
- THE USE OF A LOW WATER CUT-OFF DEVICE MAY BE REQUIRED BY STATE OR LOCAL CODES IF THE MUNCHKIN IS INSTALLED ABOVE RADIATION LEVELS.

TABLE OF CONTENTS

PART 14 thru 8

GENERAL INFORMATION

- A How It Operates4
- B Munchkin Ratings and Dimensions . .5–7
- C Pre-installation Requirements7
- D Pressure Relief Valve8

PART 29

ELECTRICAL

- A Electrical Connection9

PART 310 thru 11

GAS CONNECTION

- A Gas Connection10
- B Gas Piping10
- C Gas Table10

PART 412 thru 18

VENTING

- A Approved Venting Materials12
- B Venting the Munchkin in
3", 4" or 6" Plastic Pipe12
- C Longer Vent Runs14
- D Heater Removal from a
Common Vent System15
- E Condensate Removal16

PART 519 thru 29

PIPING

- A Expansion Tank19
- B High Velocity Circulator Pump19

PART 630 thru 34

START UP PROCEDURES

- A Sequence of Operation30
- B Items to be checked before
lighting the Munchkin30
- C Lighting Instructions31
- D Operating Instructions31
- E Adjusting the Operating Set Points
of the Munchkin VWH Display31
- F Status Menu32
- G Test Mode32
- H To Turn Off Gas to Appliance33

PART 735 thru 37

TROUBLESHOOTING

- A Munchkin Error Code35
- B Boiler Error35
- C Boiler Fault35

PART 838 thru 43

MAINTENANCE

- A Maintenance Procedures38
- B Annual Maintenance38
- C Condensate Cleaning Instructions . . .38
- D Combustion Chamber
Coil Cleaning Instructions39
- E Munchkin Controllers40

PART 1. GENERAL INFORMATION

A. HOW IT OPERATES

The Munchkin VWH is a hot water supply boiler designed to operate in conjunction with a hot water storage tank. Each Munchkin VWH is equipped with a high velocity pump to keep the unit running efficiently for many years of service. A flow switch monitors the water flow through the heat exchanger to make sure that the unit has an adequate flow rate during operation. The Munchkin VWH Controller accurately monitors the return and supply temperature that controls the output range of the Munchkin

When the system has sensed a temperature drop below the set point and minus the differential set point, The Munchkin VWH will activate the blower motor for a pre-purge of 5 seconds before going into operation. Once in operation, the Munchkin controller will now start to modulate the pre-mix burner based on analyzing the return, supply, differential and operating set point temperatures. By compiling this information, the controller utilizes an algorithm to fully adjust the firing rate while maintaining the desired output temperature. The pre-mix burner fan has direct drive current, low-voltage motor with pulse relay counting. This system allows precise control over the fan speed and combustion air volumes. Coupled with the fuel and air mixing system which are set to provide a one to one ratio of precisely measured volumes of fuel to air, an accurate and instant burner output is achieved. This keeps the Munchkin VWH running at the highest efficiency.

RECOMMENDED SERVICE CLEARANCES

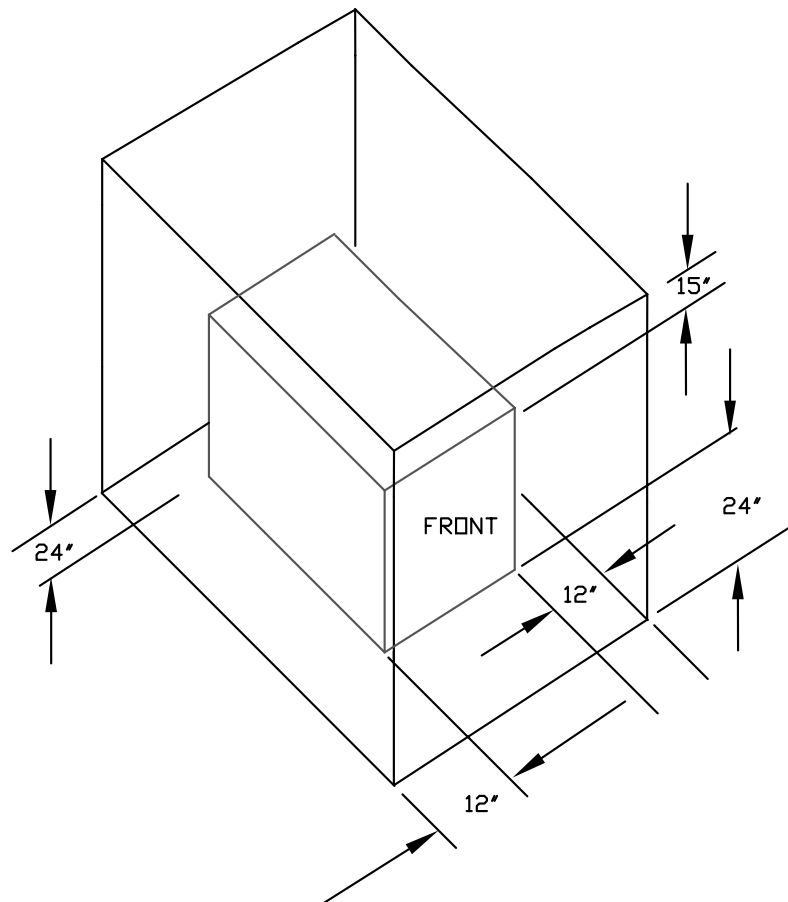

Figure 1-1

B. MUNCHKIN RATINGS AND DIMENSIONS

Model	Input Modulation	Output Modulation	Supply/Return Connection	Gas Connection Size	Intake/Exhaust Dia.	Shipping Weight	L	W	H
199VWH	66,000–199,000	48,000–191,040	1¼" NPT	¾"	3" PVC Sch. 40	126 lbs.	24.50	18.25	25.88
399VWH	100,000–399,000	96,000–383,040	2" NPT	1¼"	4" PVC Sch. 40	267 lbs.	44.25	18.25	25.88

MODEL	INLET	OUTLET	RECOVERY RATE	FIRST HOUR RATING W/ 80 GAL. STORAGE TANK	FIRST HOUR RATING W/ 119 GAL. STORAGE TANK
199 VWH	40°	80°	573 GAL	626 GAL	652 GAL
199 VWH	40°	90°	458 GAL	511 GAL	537 GAL
199 VWH	40°	100°	382 GAL	435 GAL	461 GAL
199 VWH	40°	110°	327 GAL	380 GAL	406 GAL
199 VWH	40°	120°	287 GAL	340 GAL	366 GAL
199 VWH	40°	130°	255 GAL	308 GAL	334 GAL
199 VWH	40°	140°	229 GAL	282 GAL	308 GAL
199 VWH	40°	150°	208 GAL	261 GAL	287 GAL
199 VWH	40°	160°	191 GAL	244 GAL	270 GAL
199 VWH	40°	170°	176 GAL	229 GAL	255 GAL
199 VWH	40°	180°	163 GAL	216 GAL	242 GAL

*Example recovery rate for 199VWH @ 90° rise: 400 gal. tank ÷ 255 GPH @ 90° rise = 1.56 x 60 min. = 93.6 min.

399 VWH	40°	80°	1149 GPH	1202 GAL	1228 GAL
399 VWH	40°	90°	919 GPH	972 GAL	998 GAL
399 VWH	40°	100°	766 GPH	819 GAL	845 GAL
399 VWH	40°	110°	657 GPH	710 GAL	736 GAL
399 VWH	40°	120°	575 GPH	628 GAL	654 GAL
399 VWH	40°	130°	510 GPH	563 GAL	589 GAL
399 VWH	40°	140°	460 GPH	513 GAL	539 GAL
399 VWH	40°	150°	418 GPH	471 GAL	497 GAL
399 VWH	40°	160°	383 GPH	436 GAL	462 GAL
399 VWH	40°	170°	354 GPH	407 GAL	433 GAL
399 VWH	40°	180°	328 GPH	381 GAL	407 GAL

*Example recovery rate for 399VWH @ 90° rise: 400 gal. tank ÷ 510 GPH @ 90° rise = .78 x 60 min. = 46.8 min.

199 VWH at 20GPM					
Pressure Drop for Tube Length of 1¼" Copper (10) 90° Elbows and (2) Tees (Side Outlet) with Munchkin 199 VWH					
1¼" Tube Length	20'	30'	40'	50'	60'
20 GPM	21.65	22.62	23.6	24.56	25.53

399 VWH at 40GPM					
Pressure Drop for Tube Length of 2" Copper (10) 90° Elbows and (2) Tees (Side Outlet) with Munchkin 399 VWH					
2" Tube Length	20'	30'	40'	50'	60'
40 GPM	24	24.37	24.74	25.11	25.48

DIMENSIONS

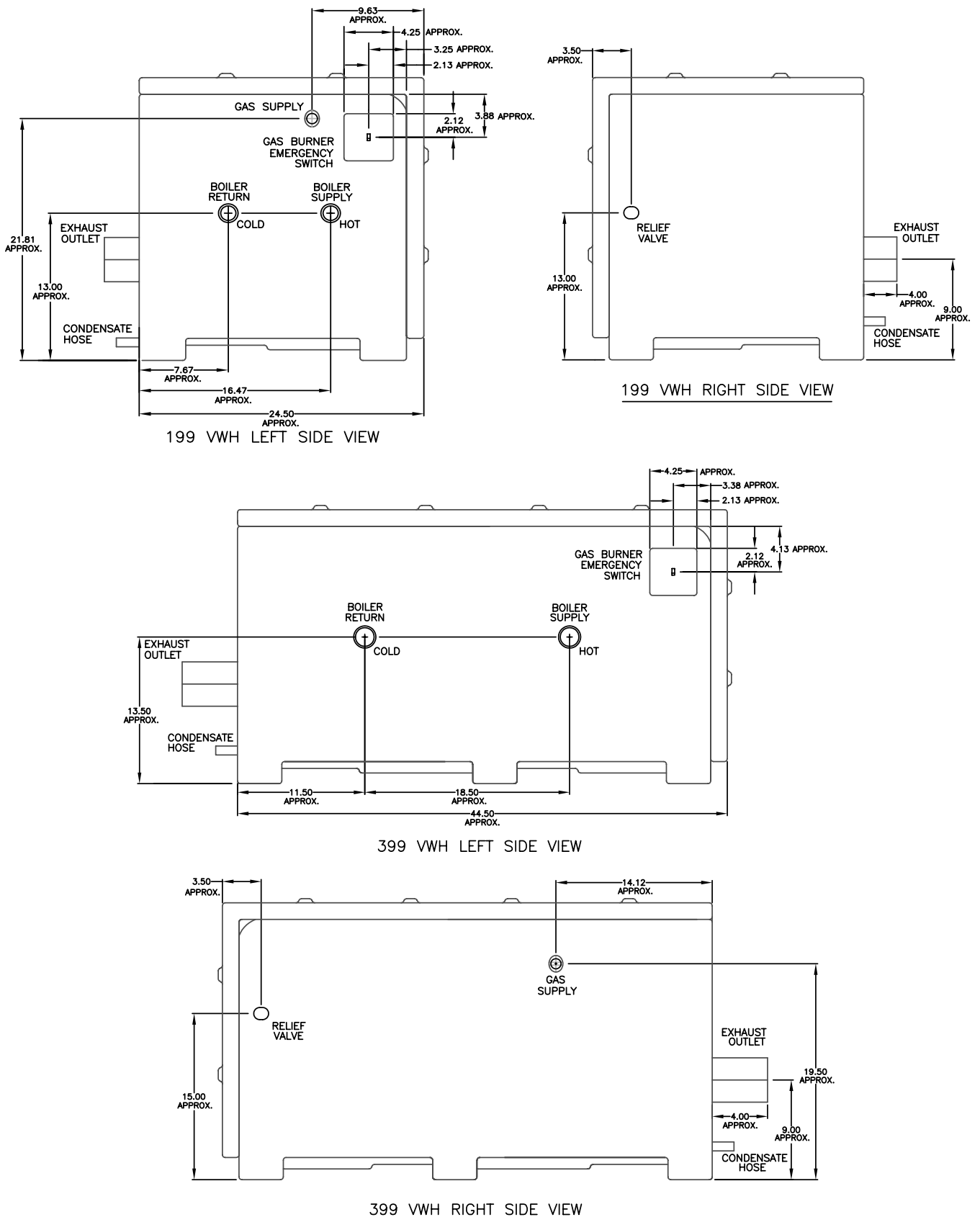
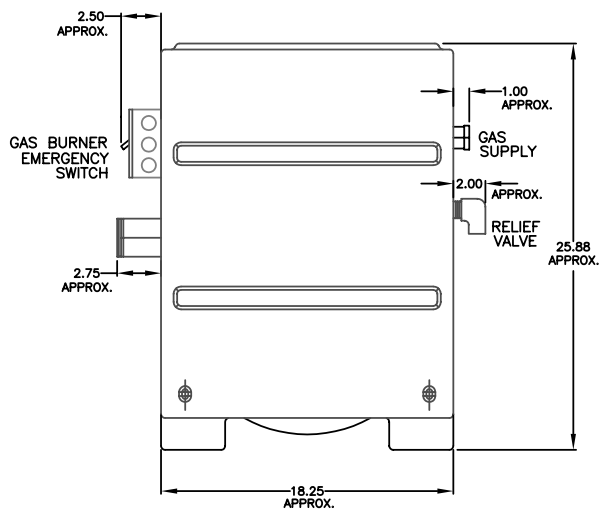
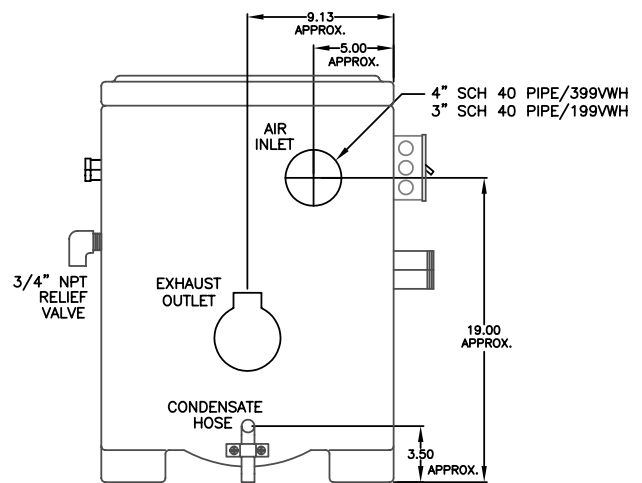

Figure 1-2



199VWH / 399 VWH FRONT VIEW



199 VWH/399 VWH BACK VIEW

Figure 1-3

C. PRE-INSTALLATION REQUIREMENTS

GENERAL

1. Munchkin VWH is supplied completely assembled as a packaged boiler. The package should be inspected for damage upon receipt and any damage to the unit should be reported to the shipping company and wholesaler. This boiler should be stored in a clean, dry area.
2. Carefully read these instructions and be sure to understand the function of all connections prior to beginning installation. Contact your Heat Transfer Products, Inc. Representative or the Heat Transfer Products, Inc. Customer Service Department for help in answering questions.
3. This boiler must be installed by a qualified contractor. The boiler warranty may be voided if the boiler is not installed correctly.

CODES & REGULATIONS

Installation and repairs are to be performed in strict accordance with the requirements of state and local regulating agencies and codes dealing with boiler and gas appliance installation.

! WARNING

Liquefied Petroleum (LP) Gas or Propane is heavier than air and, in the event of a leak, may collect in low areas such as basements or floor drains. The gas may then ignite resulting in a fire or explosion.

ACCESSIBILITY CLEARANCES

1. The Munchkin VWH is certified for closet installations with zero clearance to com-

combustible construction. In addition, it is design certified for use on combustible floors.

2. Refer to Figure 1.1 for the recommended clearance to allow for reasonable access to the boiler. Local codes or special conditions may require greater clearances.

CAUTION

Do not install this boiler on carpeting.

COMBUSTION AND VENTILATION AIR

1. The Munchkin VWH is designed only for operation with combustion air piped from outside (sealed combustion). PVC pipe must be supplied between the air inlet connection at the rear of the boiler through an outside wall.
2. No additional combustion or ventilation air is required for this appliance.
3. Refer to Section 4 of this manual, Venting, for specific instructions for piping combustion air.

PLANNING THE LAYOUT

1. Prepare sketches and notes showing the layout of the boiler installation to minimize the possibility of interferences with new or existing equipment, piping, venting and wiring.
2. The following sections of this manual should be reviewed for consideration of limitations with respect to:
 - a. Electrical Wiring: Part 2
 - b. Gas Connection: Part 3
 - c. Venting: Part 4
 - f. Piping the Munchkin VWH to the Storage Tank: Part 5

⚠ WARNING

The Munchkin is certified as an indoor appliance. Do not install the Munchkin outdoors or locate where it will be exposed to freezing temperature. This includes all related piping and components. If the Munchkin is subjected to flood water or submersed in water, the Munchkin must be replaced.

⚠ NOTICE**Service clearance of the Munchkin**

1. The front of the appliance needs 24" of clearance for service minimum. It may have a non-rated or combustible door or access panel and must have a minimum of 24" clearance.
2. The left side of the heater is 12" clearance
3. The right side of the heater is 12" clearance
4. The top of the heater is 15" clearance.

If the Munchkin is set up for liquefied petroleum (LP) gas, some geographic areas follow the Uniform Mechanical Code, section 304.6, "Liquefied petroleum gas burning appliances shall not be installed in a pit, basement or similar location where heavier-than-air gas might collect. Appliances so fueled, shall not be installed in a below grade under-floor space or basement unless such location is provided with an approved means for removal of unburned gas."

⚠ NOTICE

Condensation removal: This is a condensing, high efficiency appliance, therefore condensation removal must be addressed to avoid damage to surrounding area or appliance. See Part (4) for Condensate Requirements.

D. PRESSURE RELIEF VALVE

A pressure relief valve is installed into the right front side of the manifold. It is required that it meets the requirements of ANSI/ASME Boiler and Pressure Vessel Code, Section IV or CSA B51: Boiler Pressure Vessel and Piping Code as applicable for heating boilers. A 3/4" pipe connected to the pressure relief valve must be directed to a floor drain or suitable location within 6" of a drain or floor. To protect the valve from freezing, do not plug or cap the pressure relief valve.

⚠ DANGER

Serious explosion causing property damage and/or loss of life could result. Under no circumstances should the relief valve be eliminated, capped or plugged.

PART 2. ELECTRICAL

A. ELECTRICAL CONNECTION

The electrical connection for the Munchkin is on the left hand side of the unit. There is a ½" knockout location for an electrical connection for both the incoming power and the circulator connection. All electrical wiring must be performed by a qualified licensed electrician in accordance with National Electrical Code ANSI/NEPA to and/or the Canadian Electrical Code, Part 1 CSA C22.1, or to the applicable codes and standards. For your convenience, we have labeled all the wires that need to be connected to operate the Munchkin.

The electrical requirements are for standard 120 volts, 60 Hz 15 Amp service. This unit is wired with #18 awg and fused for no more than 15 Amps.

⚠ DANGER

IT IS EXTREMELY IMPORTANT THAT THIS UNIT BE PROPERLY GROUNDED!

⚠ DANGER

IT IS VERY IMPORTANT THAT THE BUILDING GROUND IS INSPECTED BY A QUALIFIED ELECTRICIAN PRIOR TO MAKING THIS CONNECTION!

There are two ground points in the electrical compartment that must be connected to the building ground system. Connect the building ground to the green ground screw and the green ground wire inside electrical box provided.

The Incoming power supply is connected to the Black (Hot) and the White (Neutral). The Munchkin Control board is polarity sensitive. If the polarity is reversed, the Munchkin control will not sense a flame and lock out the system.

It is important that the electrical power is not turned on at this time. Double check all connections and then turn the power on. The display that is provided with the Munchkin should now be reading the outlet temperature. Note: see Part 6/Startup Procedure section in the manual to change the temperature setting or run the heater.

PART 3. GAS CONNECTION

WARNING

Failure to follow all precautions could result in fire, explosion or death!

A. GAS CONNECTION

The gas supply shall have a maximum inlet pressure of less than 14" water column (350 mm), 1/2 pound pressure (3.5 kPa), and a minimum of 3.5" water column. The entire piping system, gas meter and regulator must be sized properly to prevent pressure drop greater than 0.5" as stated in the National Fuel Gas Code. This information is listed on the rating plate. **It is very important that you are connected to the type of gas as noted on the rating plate.** "LP" for liquefied petroleum, propane gas or, "Nat" natural or city gas. All gas connections must be approved by the local gas supplier, or utility in addition to the governing authority, prior to turning the gas supply on. The nipple provided for the 399VWH is 1 1/4" with a mandatory 1 x 1 1/4 reducing coupling (provided). Threaded into the branch of a 1 1/4" tee and a drip leg fabricated as per the national fuel gas code. The 199VWH has a 3/4" gas supply nipple with a 1/2 x 3/4 reducing coupling (provided) which is to be threaded into the branch of a 3/4" tee. **You must ensure that the entire gas line to the connection at the Munchkin is no smaller than 1 1/4" for the 399VWH and 3/4" for the 199VWH.** Once all the inspections have been performed, the piping must be leak tested. If the leak test requirement is a higher test pressure than the maximum inlet pressure, you must isolate the Munchkin from the gas line. In order to do this, you must shut the gas off using factory and field-installed gas cocks (following the lighting instructions in Part 6 Section B.) This will prevent high pressure. Failure to do so may damage the gas valve. In the event the gas valve is exposed to a pressure greater than 1/2 PSI, 14" water column, the gas valve must be replaced. **Never use an open flame (match, lighter, etc.) to check gas connections.**

B. GAS PIPING

1. Run the gas supply line in accordance with all applicable codes.
2. Locate and install manual shutoff valves in accordance with state and local requirements.

C. GAS TABLE

Refer to Table (1) to size the supply piping to minimize pressure drop between meter or regulator and unit.

Maximum Capacity of Pipe in Cubic Feet of Gas per Hour for Gas Pressures of 0.5 psi or Less and a Pressure Drop of 0.3 Inch water Column

(TABLE 1) (Based on a 0.60 Specific Gravity Gas)

Nominal Iron Pipe Size (inches)	Internal Diameter (inches)	Length of Pipe (Feet)														
		10	20	30	40	50	60	70	80	90	100	125	150	175	200.	
3/4	.824	278	190	152	130	115	105	96	90	84	79	72	64	59	55}	BTU'S
1	1.049	520	350	285	245	215	195	180	170	160	150	130	120	110	100}	PER
1 1/4	1.380	1,050	730	590	500	440	400	370	350	320	305	275	250	225	210}	HOUR
1 1/2	1.610	1,600	1,100	890	760	670	610	560	530	490	460	410	380	350	320}	X 1,000

It is recommended that a soapy solution be used to detect leaks. Bubbles will appear on the pipe to indicate a leak is present. The gas piping must be sized for the proper flow and length of pipe, to avoid pressure drop. Both the gas meter and the gas regulator must be properly sized for the total gas load. If you experience a pressure drop greater than 1" WC, the meter, regulator or gas line is undersized or in need of service. You can attach a manometer to the incoming gas drip leg, by removing the cap and installing the manometer. The gas pressure must remain between 3.5" and 14" during stand-by (static) mode and while in operating (dynamic) mode. **If an in-line regulator is used, it must be a minimum of 10 feet from the Munchkin. It is very important that the gas line is properly purged by the gas supplier or utility. Failure to properly purge the lines or improper line sizing, will result in ignition failure.** This problem is especially noticeable in NEW LP installations and also in empty tank situations. This can also occur when a utility company shuts off service to an area to provide maintenance to their lines. This gas valve must not be replaced with a conventional gas valve under any circumstances. As an additional safety feature, this gas valve has a flanged connection to the Venturi and blower.

 **WARNING**

Failure to follow all precautions could result in fire, explosion or death!

PART 4. VENTING

DANGER

It is extremely important to follow these venting instructions carefully. Failure to do so can cause severe personal injury, death or substantial property damage.

A. APPROVED VENTING MATERIALS

EXHAUST VENT

Use Plastic 3" and 4" and 6" Pipe Schedule 40 or 80.

1. Non-Foam Core PVC Pipe
2. Non-Foam Core CPVC Pipe
3. Non-Foam Core ABS Pipe

Vent Piping must conform to following

1. **PVC** Non Foam Core Pipe (Polyvinyl Chloride) to ASTM D-1784 Class 12454-B, Formerly designated Type 1, Grade 1.
2. **CPVC** (Chlorinated Polyvinyl Chloride) Class 23447-B, Formerly designated Type IV, Grade 1 conforming to ASTM D-1784.
3. **ABS** (Acrylonitrile-Butadiene-Styrene) Class 3-2-2-2-2 conforming to ASTM D3965.

DANGER

Foam Core Pipe is not to be used in connecting the exhaust pipe.

The Munchkin is a direct vent appliance. The Munchkin is listed as a Category IV Condensing Appliance. (The Munchkin Venting is rated at Zero Clearance to combustibles.)

Note: For Concrete construction or to meet certain fire codes, exhaust and inlet piping at the wall penetration to the Munchkin must be CPVC Schedule 40 or 80 to meet local fire codes. The balance from the penetrated wall to the outside, may be PVC Schedule 40 or 80.

INTAKE VENT

Use the same material as used for exhaust. Plastic Pipe or Cellular Foam Core Pipe may be used for the inlet only, **NEVER ON EXHAUST PIPING!**

WARNING

This vent system will operate with a positive pressure in the vent pipe. Do not connect vent connectors serving appliances by natural draft into any portion of mechanical draft systems.

B. VENTING THE MUNCHKIN VWH IN 3", 4" OR 6" PLASTIC PIPE

DANGER

It is extremely important to follow these venting instructions exactly. Failure to do so can cause severe personal injury, death or substantial property damage.

NOTICE

The following are code restrictions for the location of the flue gas vent terminal. Compliance to these requirements doesn't insure a satisfactory installation; good common sense must also be applied. It is important to make sure that exhaust gases are not recirculated into the inlet air of the Munchkin VWH.

The inlet pipe on the back of the cabinet is 3" for the 199 VWH and 4" for the 399 VWH. It is very important that you plan the location properly to eliminate long pipe runs and excessive fittings. Inlet pipe size must not be reduced. Do not combine the inlet air with any other inlet pipe including an inlet to an additional similar appliance. The joints must be properly cleaned, primed and cemented. The piping must also be properly supported as per Local and National Standard Plumbing Codes. It is important that the piping must be clean and free from burrs, debris, ragged ends and particles of PVC.

Exhaust piping should be sloped back to the connection on the Munchkin, at least ¼" per foot to remove additional condensate that forms within the pipe. The total combined length of pipe (intake piping plus exhaust piping added together) including elbow allowances for intake and exhaust (each elbow = 5' of pipe) should not exceed 85'. The combined vent length should not be less than a combined length of 6' plus two 90 degree elbows. Choose your vent termination locations carefully. You must also make certain that exhaust gas does not re-circulate back into the intake pipe. You must place them in an open area and follow the guidelines below.

- 1) Never vent into a walkway, patio area, alley or otherwise public area less than 7' from the ground. (See detail below references Fig. A.10.8 in the National Fuel Gas Code 2002 "Exit Terminals of Mechanical Draft and Direct-Venting Systems".)
- 2) Never vent over or under a window or over a doorway where the exhaust plume or condensation liquid will cause obtrusive or dangerous conditions. (Or refer to National Fuel Gas Code, CAN B149)
- 3) Never install a heat saver or similar product to capture waste heat from exhaust.
- 4) Always have a vent location at least 1' above maximum snow level.
- 5) Always have vent 1' above ground level, away from shrubs and bushes.
- 6) Follow local gas codes in your region or refer to National Fuel Gas Code, Can B149.
- 7) Always have at least 3' from an inside corner of outside walls, including roof overhang.
- 8) Maintain at least 4' clearance to electric, gas meters, windows, exhaust fans, chimneys, inlets or mechanical vents.
- 9) Very Important! The inlet air connection must be connected to outside air and should be located no closer than 8" to the exhaust and no further than 36".
- 10) Always place screens in all openings in intake and exhaust to prevent foreign matter from entering the Munchkin.
- 11) The vent intake and exhaust must be properly cleaned and glued for a pressure tight joint. Several methods for venting the Munchkin can be found in Figures 4-1 thru 4-6 in this section. Use these layouts as guidelines: certain site conditions such as multiple roof lines/pitches may require venting modifications (consult factory). The air inlet must be a minimum of 1' vertically above the maximum snow level. It is very important that there are no other vents, chimneys or air inlets in any direction for at least 4'.

RECOMMENDED VENTING CLEARANCES PER THE NATIONAL FUEL GAS CODE*

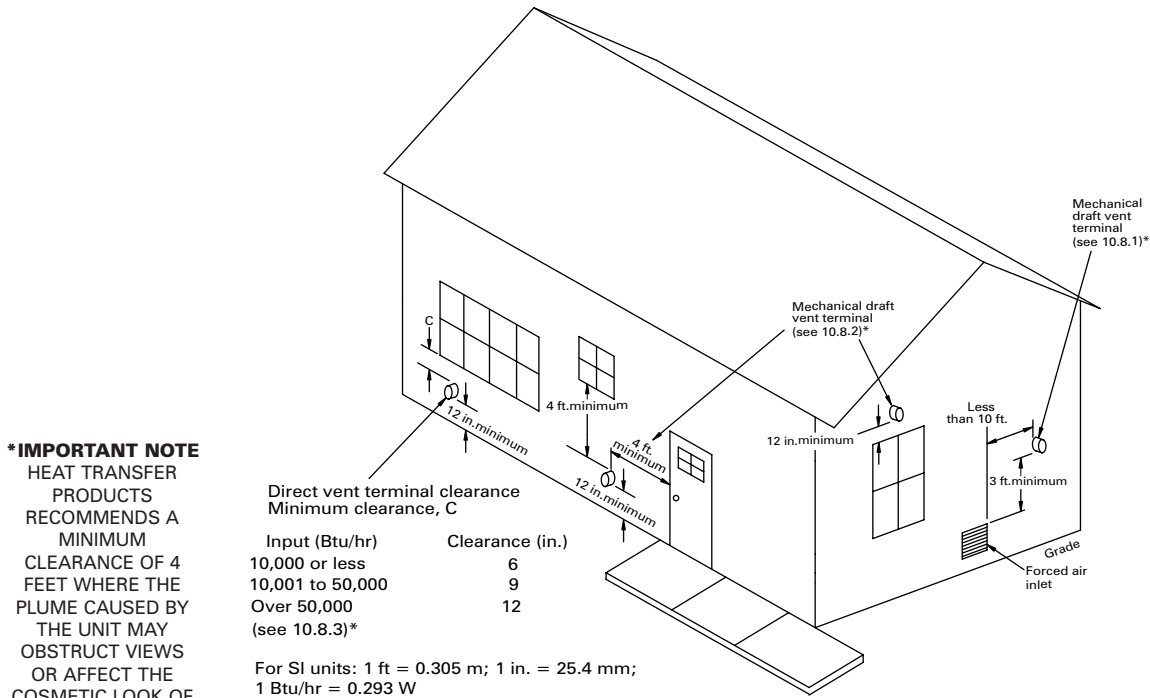

EXIT TERMINALS OF MECHANICAL DRAFT AND DIRECT-VENT VENTING SYSTEM
* REFERENCE: THE NATIONAL FUEL GAS CODE 2002 EDITION

***IMPORTANT NOTE**
HEAT TRANSFER PRODUCTS RECOMMENDS A MINIMUM CLEARANCE OF 4 FEET WHERE THE PLUME CAUSED BY THE UNIT MAY OBSTRUCT VIEWS OR AFFECT THE COSMETIC LOOK OF THE BUILDING.

CAUTION

Flue Gas will condense as it exits the vent termination. This condensate can freeze on exterior building surfaces which may cause discoloration of these surfaces. Consideration should be given to the plume of condensation that exits the exhaust which may affect the cosmetic appearance of the building.

All venting must be properly supported. The Munchkin is not intended to support any venting whatsoever. All piping, glue, solvents, cleaners, fittings and components, must conform to ASTM (American Society for Testing and Materials), and ANSI (American National Standards Institute). It is recommended that you use one of the optional vent kits specifically designed for Munchkin installations, available from Heat Transfer Products, Inc.

Example: Installation requires the following material for both inlet and exhaust piping for the Munchkin 199VWH and the 399VWH.

Required: 4 Pcs. 90 degree elbow (4 x 5 = 20 Equivalent Feet) = 20 Equivalent Feet

20' of Plastic PVC Pipe (20 x 1 = 20 Equivalent Feet) = 20 Equivalent Feet

Total Friction Loss in Equivalent Feet (20 + 20 = 40 Equivalent Feet) = 40 Equivalent Feet

C. LONGER VENT RUNS

NOTICE

Do not exceed the 125 foot maximum requirement for (intake plus exhaust piping added together). Consider fitting allowance shown in friction loss equivalent table on the following page.

! WARNING

Transitioning into a larger diameter pipe should be done in the Vertical position to avoid condensation blockage. If done in the horizontal position check to make sure condensation blockage will not occur.

The connection of air inlet and exhaust vent at the heater must remain 3" for 199VWH and 4" for 399VWH and each vent must extend from the heater a minimum of 15 equivalent feet before transitioning to a 4" vent for the 199VWH and 6" vent for the 399VWH. The overall extended maximum length of pipe on the inlet and exhaust combined, must not exceed 125 equivalent feet. Listed below are the 3", 4" and 6" size equivalent table.

Friction Loss Equivalent in Piping and Fittings		
Fittings or Piping		Equivalent Feet
90 degree elbow	=	5
45 degree elbow	=	3
Coupling	=	0
air inlet tee	=	0
Plastic Pipe	=	1
concentric vent kit	=	3
vent kit	=	0

Example: Installation requires the following material for both the inlet and exhaust piping when **extending** the vent run for the Munchkin 199VWH.

3" Vented Appliance

2 Pcs. – 3" 90 degree elbow (2 x 5 = 10 Equivalent Feet) = 10 Equivalent Feet
 20' of 3" Plastic PVC Pipe (20 x 1 = 20 Equivalent Feet) = 20 Equivalent Feet
Total of 3" Equivalent Piping with Fittings = 30 Equivalent Feet

Requirements for 4" Venting

6 Pcs. – 4" 90 degree elbows (6 x 3 = 18 Equivalent Feet) = 18 Equivalent Feet
 4 Pcs. – 4" 45 degree elbows (4 x 1 = 4 Equivalent Feet) = 4 Equivalent Feet
 40' of 4" Plastic PVC Pipe (40 x 1 = 40 Equivalent Feet) = 40 Equivalent Feet
Total of 4" Equivalent Piping with Fittings = 62 Equivalent Feet

Total Friction Loss in Equivalent Feet for both 3" and 4" (30 + 62 = 92 Equivalent Feet) = 92 Equivalent Feet

! DANGER

The Munchkin is not intended to be common vented with any other existing appliance!

D. HEATER REMOVAL FROM A COMMON VENT SYSTEM

At the time of removal of an existing heater, the following steps shall be followed with each appliance remaining connected to the common venting system placed in operation, while the other appliances remaining connected to common venting system are not operating.

1. Seal any unused openings in the common venting system.
2. Visually inspect the venting system for proper size and horizontal pitch to determine if there is blockage, leakage, corrosion or other deficiencies that could cause an unsafe condition.

3. If practical, close all building doors, windows and all doors between the space in which the appliance remains connected to the common venting system located and other spaces in the building. Turn on clothes dryers and any appliances not connected to the common venting system. Turn on any exhaust fans, such as range hoods and bathroom exhausts, at maximum speed. Do not operate a summer exhaust fan. Close all fireplace dampers.
4. Place in operation the appliance being inspected. Follow the lighting instructions. Adjust the thermostat so the appliance will operate continuously.
5. Test for spillage at the draft hood relief opening after 5 minutes of main burner operation. Use the flame of a match or candle or smoke from a cigarette.
6. After it has been determined that each appliance remaining connected to common venting system properly vents when tested as outlined, return doors, windows, exhaust fans, fireplace dampers and any other gas burning appliance to their previous condition of use.
7. Any improper operation of the common venting system should be corrected so the installation conforms with the National Fuel Gas Code, ANSI Z223.1. When resizing any portion of the common venting system, the common venting system should be resized to approach the minimum size as determined using the appropriate tables in Appendix G in the National Fuel Gas Code , ANSI Z 223.1

E. CONDENSATE REMOVAL

This is a condensing high efficiency appliance, therefore this unit has a condensate removal system. Condensate is nothing more than water vapor, derived from the combustion products, similar to an automobile when it is initially started. It is very important that the condensate line is sloped away from and down to a suitable inside drain, if the condensate outlet on the Munchkin is lower than the drain, you must use a condensate removal pump (kit available from Heat Transfer Products, Inc.) A condensate filter, if required by local authorities, can be made up of lime crystals, marble or phosphate chips will neutralize the condensate. This can be done in the field by the installer or you may purchase one from Heat Transfer Products, Inc. It is also very important that the condensate line is not exposed to freezing temperatures, or any other type of blockage. Plastic tubing should be the only material used for the condensate line. Steel, brass, copper or others will be subject to corrosion or deterioration. A second vent may be necessary to prevent condensate line vacuum lock if a long horizontal run is used. An increase to 1" tubing may be necessary.

DIAGRAMS FOR SIDEWALL VENTING

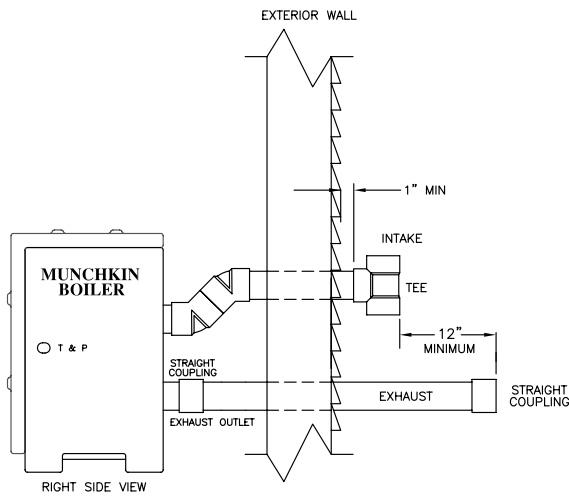

Figure 4-1: Sidewall Vent with Tee (Intake) & Coupling (Exhaust) for standard floor units

**3" piping for 199VWH
4" piping for 399VWH**

****IMPORTANT NOTE:** All vent pipes must be glued, properly supported and the exhaust must be pitched a minimum of a 1/4" per foot back to the boiler (to allow drainage of condensate). Always increase pipe in vertical position. Never increase pipe size in horizontal position.

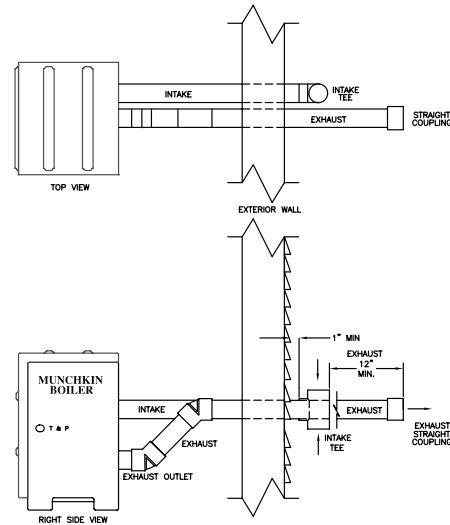

Figure 4-2: Sidewall Vent with Tee (Intake) & Coupling (Exhaust) for standard floor units

**3" piping for 199VWH
4" piping for 399VWH**

****IMPORTANT NOTE:** All vent pipes must be glued, properly supported and the exhaust must be pitched a minimum of a 1/4" per foot back to the boiler (to allow drainage of condensate). Always increase pipe in vertical position. Never increase pipe size in horizontal position.

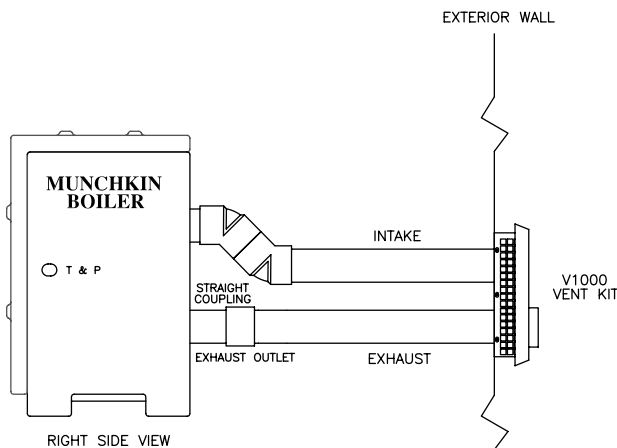

Figure 4-3: Sidewall Vent with V1000 or V2000 kit for standard floor units

**3" piping for 199VWH
4" piping for 399VWH**

****IMPORTANT NOTE:** All vent pipes must be glued, properly supported and the exhaust must be pitched a minimum of a 1/4" per foot back to the boiler (to allow drainage of condensate). Always increase pipe in vertical position. Never increase pipe size in horizontal position.

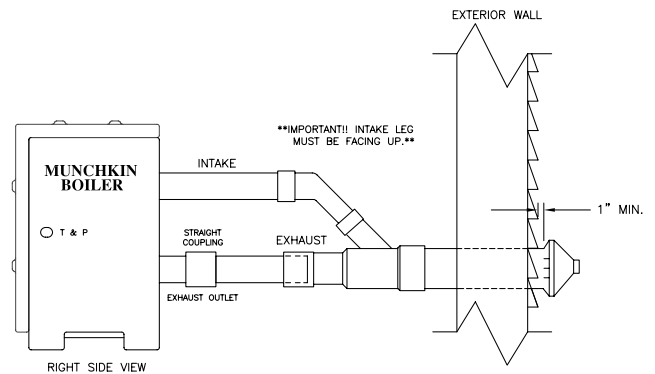

Figure 4-4: Sidewall Vent with 3" concentric vent kit (KGAVT0601CVT) for standard floor units

3" piping for 199VWH

****IMPORTANT NOTE:** All vent pipes must be glued, properly supported and the exhaust must be pitched a minimum of a 1/4" per foot back to the boiler (to allow drainage of condensate). Always increase pipe in vertical position. Never increase pipe size in horizontal position.

DIAGRAMS FOR VERTICAL VENTING

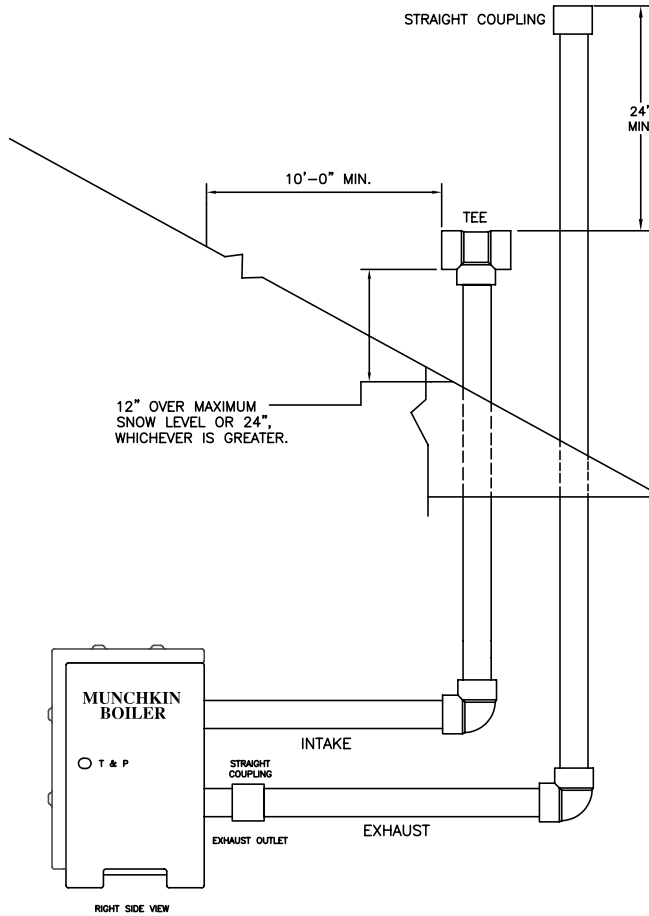

Figure 4-5: Roof Vent with tee (intake) & coupling (exhaust) for standard floor units

**3" piping for 199VWH
4" piping for 399VWH**

****IMPORTANT NOTE:** All vent pipes must be glued, properly supported and the exhaust must be pitched a minimum of a 1/4" per foot back to the boiler (to allow drainage of condensate). Always increase pipe in vertical position. Never increase pipe size in horizontal position.

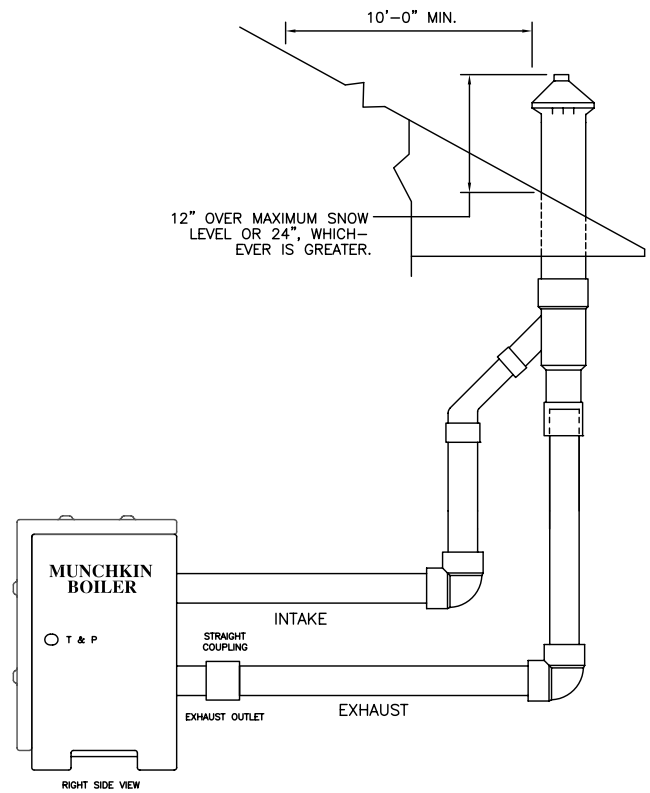

Figure 4-6: Roof Vent with 3" concentric vent kit (KGAVT0601CVT) for standard floor units

3" piping for 199VWH

****IMPORTANT NOTE:** All vent pipes must be glued, properly supported and the exhaust must be pitched a minimum of a 1/4" per foot back to the boiler (to allow drainage of condensate). Always increase pipe in vertical position. Never increase pipe size in horizontal position.

PART 5. PIPING THE MUNCHKIN VWH TO THE STORAGE TANK

WARNING

When raising tank temperature, you increase the risk of scalding – Please use a water tempering or mixing valve and extreme caution. Consult codes for conformance.

WARNING

Plumbing of this product should only be done by a qualified, licensed plumber in accordance with all local plumbing codes.

The Munchkin is designed to be connected to a storage tank to supply domestic hot water. Heat Transfer Products has available storage tanks that are 80/119 gallon size storage tanks constructed in either Stainless Steel or Glass lined construction. These storage tanks will be directly connected to the Munchkin VWH supply and return connection. Connect the cold water supply to both the storage bottom port and the supply side of the Munchkin VWH (shown in Piping details, this section) It is important that you install a flow check on the supply line of Munchkin VWH before you connect feed line to the storage. This will allow the cold feed to flow through the storage tank first and not the Munchkin VWH. It is recommended that you install shut off valves on the cold feed line for ease of future service. If there is a back flow preventer, or any type of no return valve in the system, then you must install an additional tee for a suitable potable hot water expansion tank. Connect the Storage tank return line to the return connection located on the Munchkin VWH (shown in Piping details, this section). Then connect your hot water outlet located on the storage tank to your hot water plumbing lines.

WARNING

NEVER USE DIELECTRIC UNIONS OR GALVANIZED STEEL FITTINGS WHEN CONNECTING TO A STAINLESS STEEL STORAGE TANK.

A. EXPANSION TANK

A potable hot water expansion tank may be required to offset the water expansion as the water is heated. In most city plumbing systems, the water meter has a no return or back flow device built into the system to prevent a back flow of water back into city mains. Some states require back flow preventers on all incoming water supplies. Under these circumstances, you will need a hot water expansion tank listed for potable water use. The expansion tank should be located on the cold inlet piping close to the water heater. It is important that you follow the expansion tank manufacturer's installation guidelines when installing any expansion tank.

See the piping illustrations included in this section, Figs. 5-2 to 5-9 for suggested guidelines in piping the Munchkin heater with either zone valves or circulator pumps.

**Please note that these illustrations are meant to show system piping concept only, the installer is responsible for all equipment and detailing required by local codes.*

B. HIGH VELOCITY CIRCULATOR PUMP

Every Munchkin VWH is shipped with a high velocity circulating pump to assure the correct amount of continuous flow through the all stainless steel heat exchanger at all times. If a replacement of the high velocity circulator pump is needed, it must match the performance of the pump provided with the Munchkin VWH package. NOTE: The circulator must be designed for potable water systems.

C. CIRCULATOR SIZING

The Munchkin VWH Heat Exchanger has a pressure drop which must be considered in your system design. Refer to the graph below for pressure drop through the Munchkin VWH Heat Exchanger.

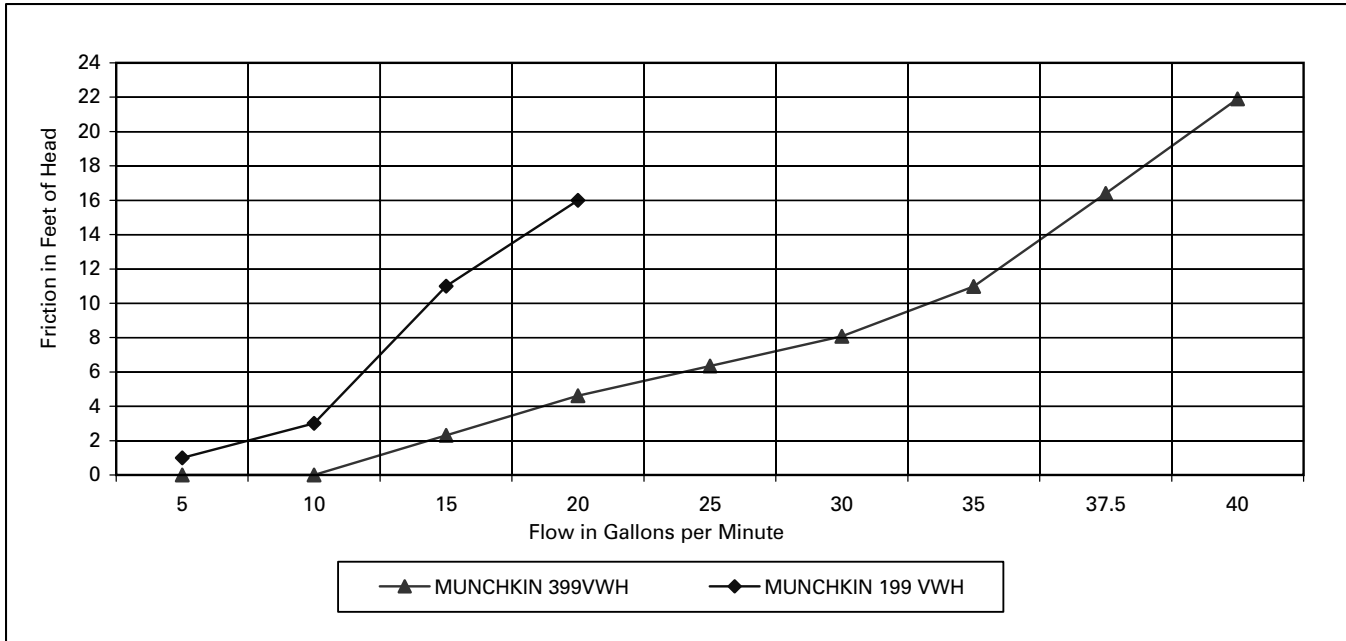















*The recommended circulators are based on 1 gpm per 10,000 BTU/hr w/20

Circulator Sizing Chart			
BOILER	TACO P/N	GRUNDFOS P/N	Bell & Gosset t
199M	0011	26-96	PL-36
399M	1400-60	UPS 32-160	PL-55

PIPING ILLUSTRATIONS

Piping Symbol Legend

- | | | | |
|--|--|---|--|
|  | circulator (open loop)
(w/ isolation flanges) |  | anti-scald rated
mixing valve |
|  | flow switch |  | pressure gauge |
|  | gate valve |  | pressure relief valve
(or P&T relief valve) |
|  | globe valve |  | temperature /
pressure gauge |
|  | ball valve |  | union |
|  | swing-check valve |  | vacuum breaker |
|  | spring-loaded check valve | | |
|  | hose bib / boiler drain | | |

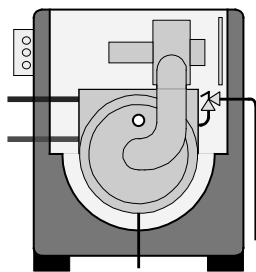
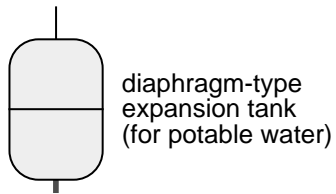

Munchkin heater

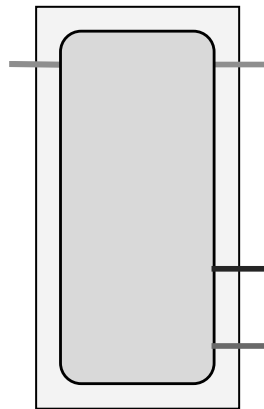

Superstor Ultra
Storage Tank

Fig. 5-1

Volume Water Heating using Munchkin boiler (1 boiler supplying one storage tank)

Drawing VWH 1/1

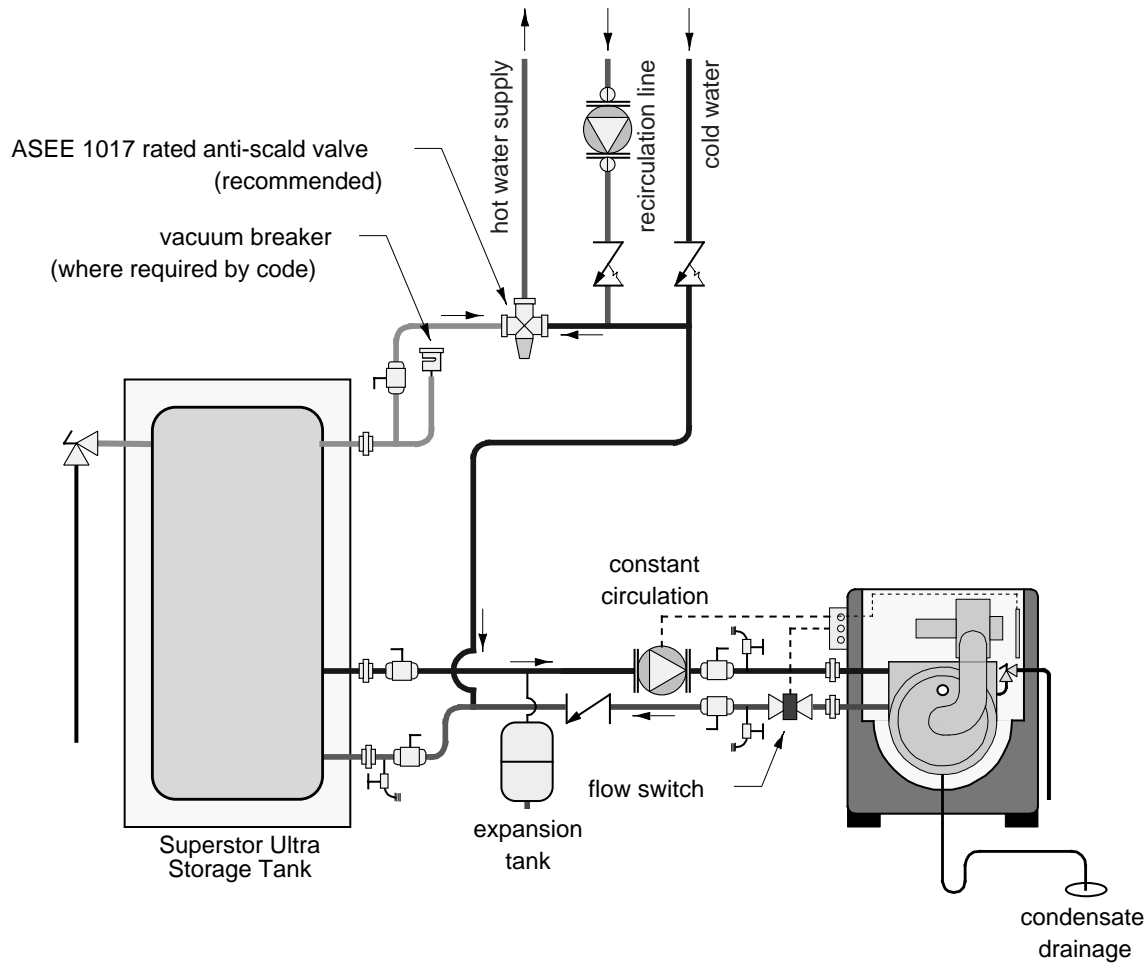

NOTES:

1. This drawing is meant to show system piping concept only. Installer is responsible for all equipment & detailing required by local codes.
2. Boiler circulator must be rated for open loop application. Do not use cast-iron circulators
3. Boiler circulator(s) operate continuously
4. The minimum pipe size for connecting to a water storage tank is 1 inch.
5. The minimum pipe size for connecting a Munchkin boiler is 1.25 inches for 199 VWH, and 2-inches for 399 VWH
6. All pumps are shown with isolation flanges or full port ball valves for isolation. The alternative is standard flanges with full port ball valves and a separate flow check valve.
7. Install a minimum of 12 diameters of straight pipe upstream of all circulators and check valves.
8. Install vacuum relief valve in accordance with local code requirements
9. All multiple boilers and multiple storage tanks shall be installed with reverse return piping as shown
10. Anti-scald rated mixing valve is recommended on all tanks if the leaving hot water temperature from tank is above 119 °F.
11. Expansion tank must be rated for use with potable water

Fig. 5-2

Volume Water Heating using Munchkin boiler (1 boiler supplying two storage tanks)

Drawing VWH 1/2

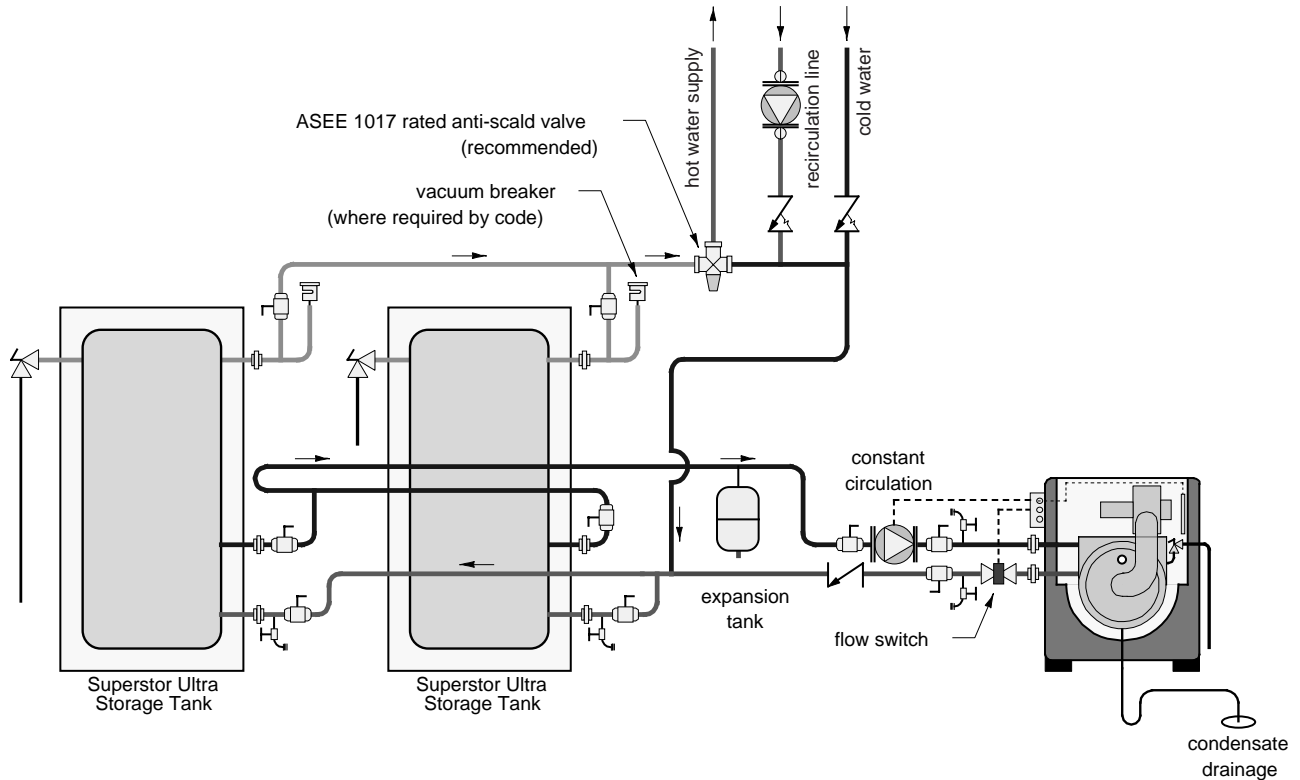

NOTES:

1. This drawing is meant to show system piping concept only. Installer is responsible for all equipment & detailing required by local codes.
2. Boiler circulator must be rated for open loop application. Do not use cast-iron circulators
3. Boiler circulator(s) operate continuously
4. The minimum pipe size for connecting to a water storage tank is 1 inch.
5. The minimum pipe size for connecting a Munchkin boiler is 1.25 inches for 199 VWH, and 2-inches for 399 VWH
6. All pumps are shown with isolation flanges or full port ball valves for isolation. The alternative is standard flanges with full port ball valves and a separate flow check valve.
7. Install a minimum of 12 diameters of straight pipe upstream of all circulators and check valves.
8. Install vacuum relief valve in accordance with local code requirements
9. All multiple boilers and multiple storage tanks shall be installed with reverse return piping as shown
10. Anti-scald rated mixing valve is recommended on all tanks if the leaving hot water temperature from tank is above 119 °F.
11. Expansion tank must be rated for use with potable water

Fig. 5-3

Volume Water Heating using Munchkin boiler (2 boilers supplying one storage tank)

Drawing VWH 2/1 H

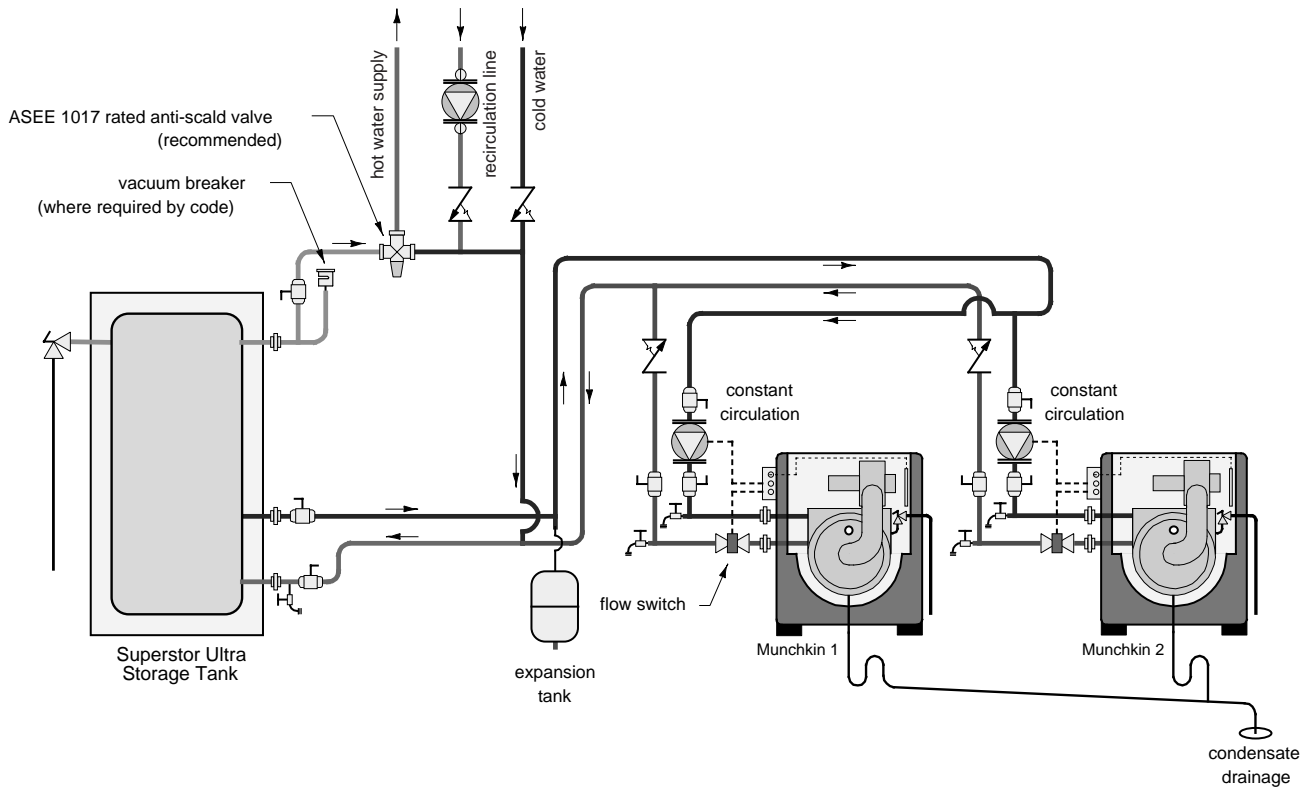

NOTES:

1. This drawing is meant to show system piping concept only. Installer is responsible for all equipment & detailing required by local codes.
2. Boiler circulator must be rated for open loop application. Do not use cast-iron circulators
3. Boiler circulator(s) operate continuously
4. The minimum pipe size for connecting to a water storage tank is 1 inch.
5. The minimum pipe size for connecting a Munchkin boiler is 1.25 inches for 199 VWH, and 2-inches for 399 VWH
6. All pumps are shown with isolation flanges or full port ball valves for isolation. The alternative is standard flanges with full port ball valves and a separate flow check valve.
7. Install a minimum of 12 diameters of straight pipe upstream of all circulators and check valves.
8. Install vacuum relief valve in accordance with local code requirements
9. All multiple boilers and multiple storage tanks shall be installed with reverse return piping as shown
10. Anti-scald rated mixing valve is recommended on all tanks if the leaving hot water temperature from tank is above 119 °F.
11. Expansion tank must be rated for use with potable water

Fig. 5-4

Volume Water Heating using Munchkin boiler (2 boilers supplying one storage tank)

Drawing VWH 2/1 V

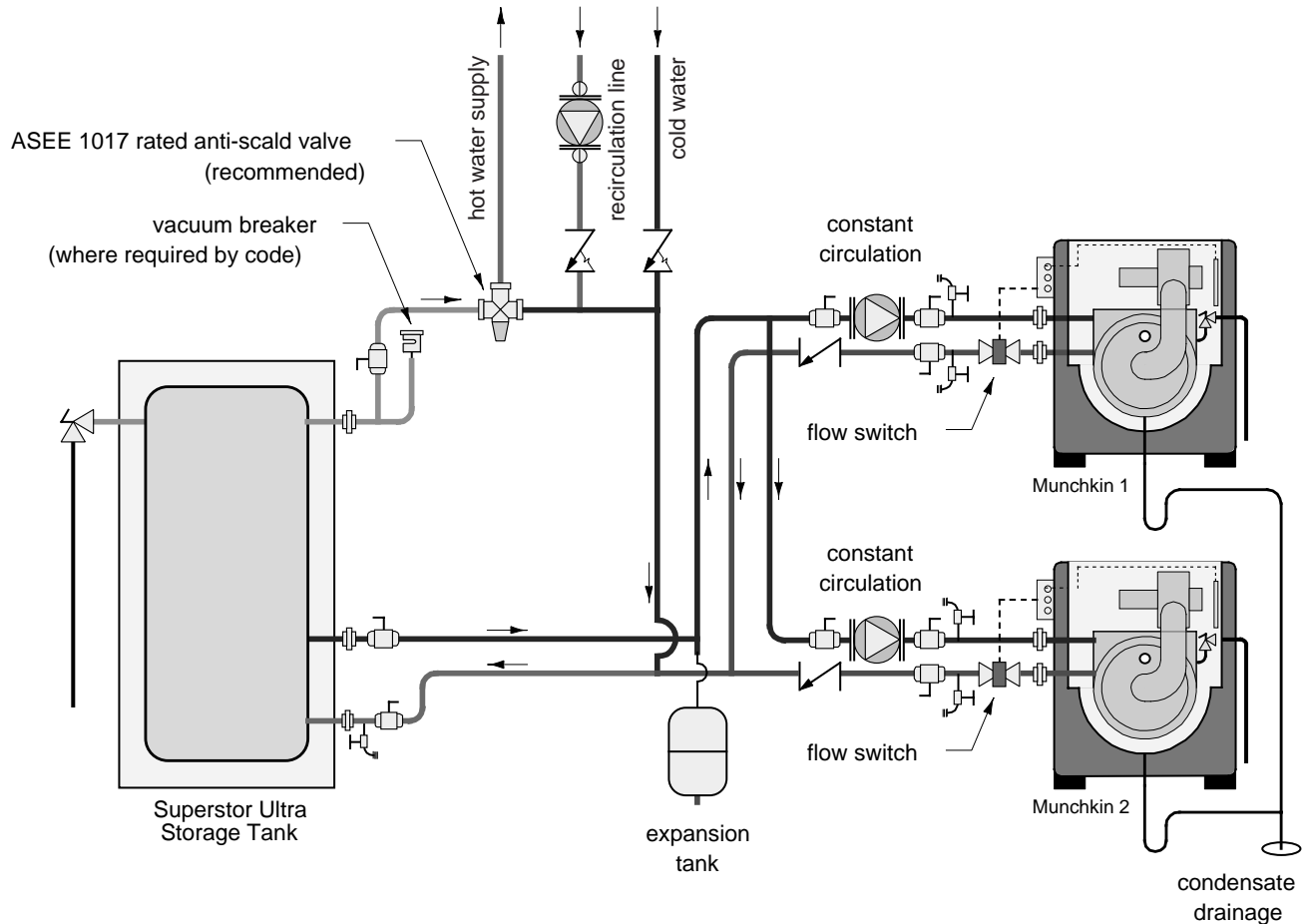

NOTES:

1. This drawing is meant to show system piping concept only. Installer is responsible for all equipment & detailing required by local codes.
2. Boiler circulator must be rated for open loop application. Do not use cast-iron circulators
3. Boiler circulator(s) operate continuously
4. The minimum pipe size for connecting to a water storage tank is 1 inch.
5. The minimum pipe size for connecting a Munchkin boiler is 1.25 inches for 199 VWH, and 2-inches for 399 VWH
6. All pumps are shown with isolation flanges or full port ball valves for isolation. The alternative is standard flanges with full port ball valves and a separate flow check valve.
7. Install a minimum of 12 diameters of straight pipe upstream of all circulators and check valves.
8. Install vacuum relief valve in accordance with local code requirements
9. All multiple boilers and multiple storage tanks shall be installed with reverse return piping as shown
10. Anti-scald rated mixing valve is recommended on all tanks if the leaving hot water temperature from tank is above 119 °F.
11. Expansion tank must be rated for use with potable water

Fig. 5-5

Volume Water Heating using Munchkin boilers (2 boilers supplying two storage tanks)

Drawing VWH2/2 H

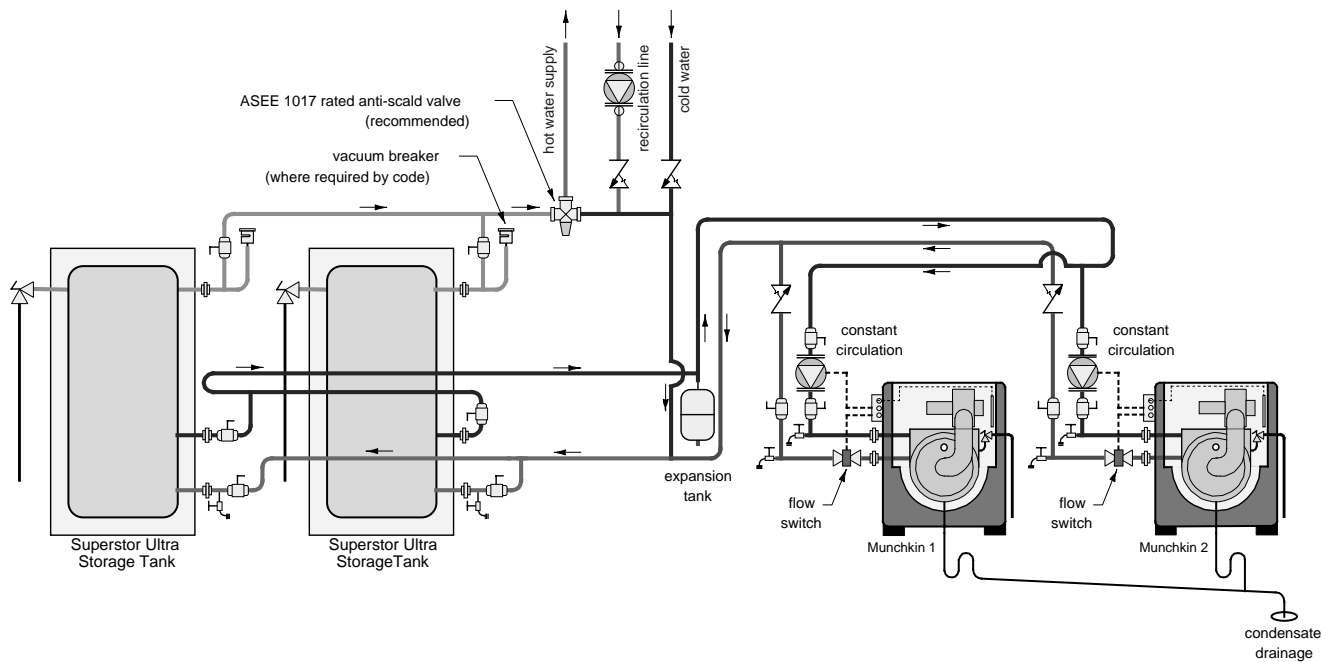

NOTES:

1. This drawing is meant to show system piping concept only. Installer is responsible for all equipment & detailing required by local codes.
2. Boiler circulator must be rated for open loop application. Do not use cast-iron circulators
3. Boiler circulator(s) operate continuously
4. The minimum pipe size for connecting to a water storage tank is 1 inch.
5. The minimum pipe size for connecting a Munchkin boiler is 1.25 inches for 199 VWH, and 2-inches for 399 VWH
6. All pumps are shown with isolation flanges or full port ball valves for isolation. The alternative is standard flanges with full port ball valves and a separate flow check valve.
7. Install a minimum of 12 diameters of straight pipe upstream of all circulators and check valves.
8. Install vacuum relief valve in accordance with local code requirements
9. All multiple boilers and multiple storage tanks shall be installed with reverse return piping as shown
10. Anti-scald rated mixing valve is recommended on all tanks if the leaving hot water temperature from tank is above 119 °F.
11. Expansion tank must be rated for use with potable water

Fig. 5-6

Volume Water Heating using Munchkin boilers (2 boilers supplying two storage tanks)

Drawing VWH2/2 V

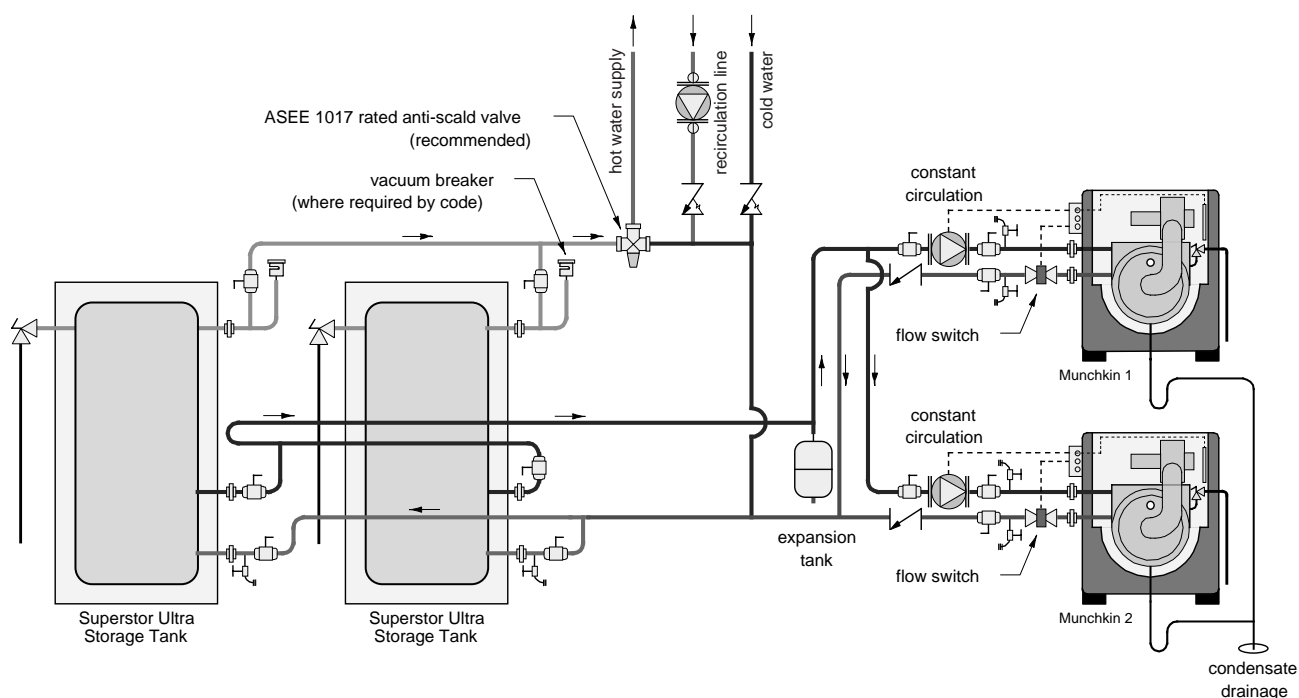

NOTES:

1. This drawing is meant to show system piping concept only. Installer is responsible for all equipment & detailing required by local codes.
2. Boiler circulator must be rated for open loop application. Do not use cast-iron circulators
3. Boiler circulator(s) operate continuously
4. The minimum pipe size for connecting to a water storage tank is 1 inch.
5. The minimum pipe size for connecting a Munchkin boiler is 1.25 inches for 199 VWH, and 2-inches for 399 VWH
6. All pumps are shown with isolation flanges or full port ball valves for isolation. The alternative is standard flanges with full port ball valves and a separate flow check valve.
7. Install a minimum of 12 diameters of straight pipe upstream of all circulators and check valves.
8. Install vacuum relief valve in accordance with local code requirements
9. All multiple boilers and multiple storage tanks shall be installed with reverse return piping as shown
10. Anti-scald rated mixing valve is recommended on all tanks if the leaving hot water temperature from tank is above 119 °F.
11. Expansion tank must be rated for use with potable water

Fig. 5-7

Volume Water Heating using Munchkin boiler (3 boilers supplying two storage tanks)

Drawing VWH 3/2 H

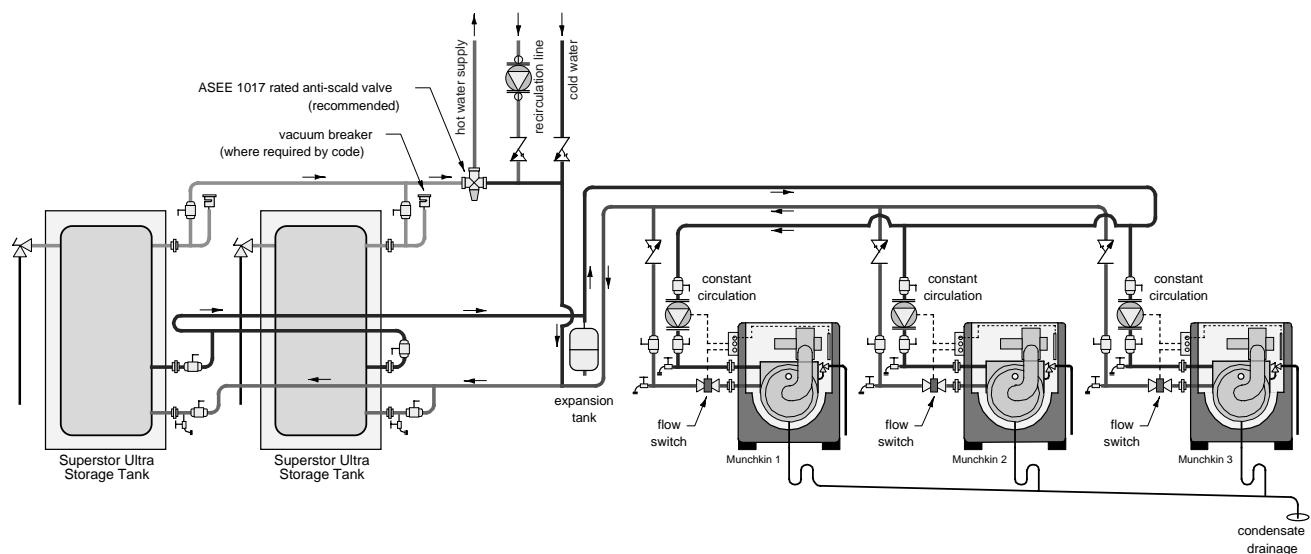

NOTES:

1. This drawing is meant to show system piping concept only. Installer is responsible for all equipment & detailing required by local codes.
2. Boiler circulator must be rated for open loop application. Do not use cast-iron circulators
3. Boiler circulator(s) operate continuously
4. The minimum pipe size for connecting to a water storage tank is 1 inch.
5. The minimum pipe size for connecting a Munchkin boiler is 1.25 inches for 199 VWH, and 2-inches for 399 VWH
6. All pumps are shown with isolation flanges or full port ball valves for isolation. The alternative is standard flanges with full port ball valves and a separate flow check valve.
7. Install a minimum of 12 diameters of straight pipe upstream of all circulators and check valves.
8. Install vacuum relief valve in accordance with local code requirements
9. All multiple boilers and multiple storage tanks shall be installed with reverse return piping as shown
10. Anti-scald rated mixing valve is recommended on all tanks if the leaving hot water temperature from tank is above 119 °F.
11. Expansion tank must be rated for use with potable water

Fig. 5-8

Volume Water Heating using Munchkin boiler (3 boilers supplying two storage tanks)

Drawing VWH 3/2 V

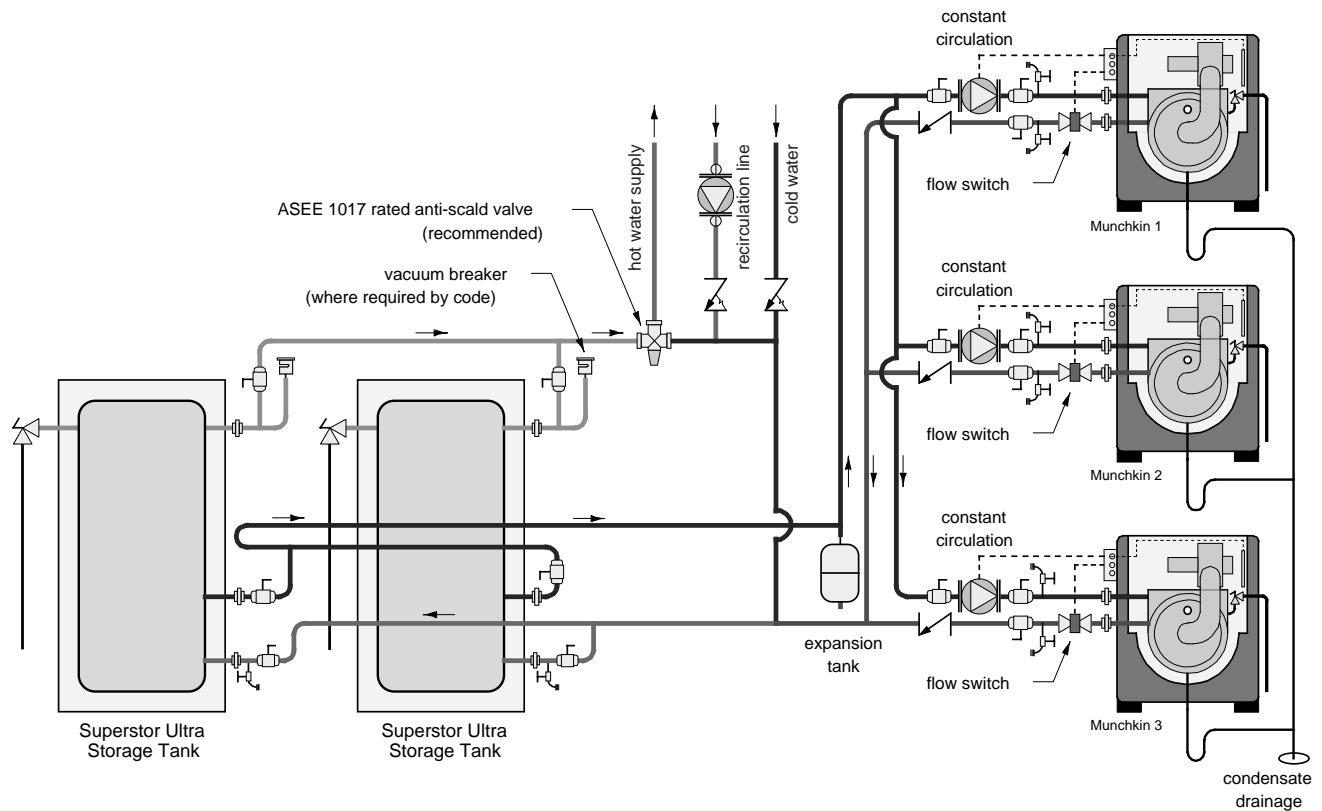

NOTES:

1. This drawing is meant to show system piping concept only. Installer is responsible for all equipment & detailing required by local codes.
2. Boiler circulator must be rated for open loop application. Do not use cast-iron circulators
3. Boiler circulator(s) operate continuously
4. The minimum pipe size for connecting to a water storage tank is 1 inch.
5. The minimum pipe size for connecting a Munchkin boiler is 1.25 inches for 199 VWH, and 2-inches for 399 VWH
6. All pumps are shown with isolation flanges or full port ball valves for isolation. The alternative is standard flanges with full port ball valves and a separate flow check valve.
7. Install a minimum of 12 diameters of straight pipe upstream of all circulators and check valves.
8. Install vacuum relief valve in accordance with local code requirements
9. All multiple boilers and multiple storage tanks shall be installed with reverse return piping as shown
10. Anti-scald rated mixing valve is recommended on all tanks if the leaving hot water temperature from tank is above 119 °F.
11. Expansion tank must be rated for use with potable water

Fig. 5-9

PART 6. START-UP PROCEDURES

A. SEQUENCE OF OPERATION

1. When power is first applied to the control, the control display will read the outlet temperature. The control will initially run through a self-diagnostic routine and then go into its operating mode. If there is no call for heat, the System will go into an idle state. The circulator must be wired to incoming power to operate continuously. If there is a code **FL** in the display window, then either the circulator is not operating or there is a restriction in the piping system, rendering an inadequate flow.
2. The control then performs selected system diagnostic checks. If all checks are successfully passed, a pre-purge cycle is initiated (the blower will be on maximum speed).
3. When the actual temperature is below a set-point, minus the switching differential, the burner will operate and modulate to heat the system.
4. When the pre-purge period is complete, power is applied to the spark ignitor for approximately 6 seconds. Approximately 2 seconds later, we verify flame. If a flame is not verified during the trial-for-ignition, the gas valve is immediately closed and the control will return to step 2. After three trials, if a flame is not verified, the control will go into a lockout mode. If a flame is confirmed, the control enters the heating mode. The fire rate will be based on the proprietary algorithm.
5. When water temperature reaches the temperature set point, the gas valve is closed and the control enters a post-purge state (the blower will be on maximum speed).
6. When the post-purge is complete, the control enters an idle state while continuing to monitor temperature and the state of other system devices. If a call-for-heat is received, the control will automatically return to step 2 in sequence and repeat the entire operating cycle.

B. ITEMS TO BE CHECKED BEFORE LIGHTING THE MUNCHKIN

It is recommended that you read the General Information Section (Part 1) to get a better understanding how the Munchkin operates before you start the unit.

1. Make sure that you follow the Lighting instruction before running the Munchkin.
2. Check to see if all the electrical connections are on securely.
3. Make sure that the Gas is turned on inside the cabinet and outside of the Munchkin.
4. Double check the temperature setting (Note: The Munchkin is factory set at 119 degrees)
5. Make sure the unit is properly grounded and the electrical wiring meets the requirements of the electrical section (Part 2).
6. Turn on the power to the Munchkin. The Temperature of the Munchkin Outlet will appear in the display provided. If a fault code appears, correct the fault before operating. Make sure that the flow switch is connected and adjust the setpoint for the desired water temperature. The Munchkin will now run its pre-purge cycle, then begin running, which will be indicated by the Green light illuminating under "Flame On" in your display.

WARNING

If you do not follow these instructions exactly, a fire or explosion may result, causing property damage, personal injury or loss of life.

C. LIGHTING INSTRUCTIONS

FOR YOUR OWN SAFETY READ BEFORE OPERATING

1. This appliance does not have pilot. It is equipped with an ignition device which automatically lights the burner. Do not try to light the burner by hand.
2. BEFORE OPERATING smell all around the appliance area for gas. Be sure to smell next to the floor because some gas is heavier than air and will settle on the floor.

WHAT TO DO IF YOU SMELL GAS

- Do not try to light any appliance.
 - Do not touch any electric switch; do not use any phone in your building.
 - Immediately call your gas supplier from a neighbor's phone. Follow the gas suppliers' instructions.
 - If you cannot reach your gas supplier, call the fire department.
3. Turn on gas shutoff valve (located inside of the Heater) so that the handle is aligned with the gas pipe. If the handle will not turn by hand, don't try to repair it, call a qualified service technician. Force or attempted repair may result in a fire or explosion.
 4. Do not use this appliance if any part has been under water. Immediately call a qualified service technician to inspect the appliance and to replace any part of the control system and any gas control which has been under water.
 5. The Munchkin Heater shall be installed so the gas ignition system components are protected from water (dripping, spraying, rain, etc.) during appliance operation and service (circulator replacement, condensate trap, control replacement, etc.)

D. OPERATING INSTRUCTIONS

1. STOP! Read the safety information in Part 6.
2. Turn off all electric power to the appliance.
3. This appliance is equipped with an ignition device which automatically lights the burner. Do not try to light the burner by hand.
4. Remove front cover.
5. Turn gas shutoff valve to "off" position.
6. Wait five (5) minutes to clear out any gas. If you then smell gas, STOP! Follow Part 6, Section B/Lighting Instructions in the safety information. If you don't smell gas, go to the next step.
7. Turn the gas shutoff valve to "on" position.
8. Replace the Front Cover.
9. Turn on all electric power to appliance.
10. Set the temperature to the desired setting.
11. If the appliance will not operate, follow the instructions "To Turn Off Gas To Appliance" Section E and call your service technician or gas supplier.

E. ADJUSTING THE OPERATING SET POINTS OF THE MUNCHKIN VWH DISPLAY

To adjust a set point value on the Munchkin VWH, Simply press the **S3/Program** key for three seconds until you see **dd** then an alternating value of 119° F. This will be your first function. To advance to the next function, simply press the **S3/program** (see set point adjustment chart on next page). Any function setting may be changed by pressing either the **S1/-** or the **S2/+** key on the display. After advancing through the function, press the **S3/Program** key, this will bring you back to normal operation, displaying the output temperature of the Munchkin VWH.

COMBUSTION SETTINGS — 199VWH / 399 VWH HIGH FIRING RATES and LOW FIRING RATES ON ALL MODELS				
	Natural Gas		Propane LP	
	low	high	low	high
Carbon CO ppm Monoxide	0–20 ppm	70 ppm–135 ppm	0–20 ppm	70–150 ppm
Carbon CO ^{2%} Dioxide	8-1/2% – 9-1/2%	8-1/2% – 9-1/2%	9-1/2% – 10-1/2%	9-1/2% – 10-1/2%

Fig. 6-1

H. TO TURN OFF GAS TO APPLIANCE

1. Set the thermostat to lowest setting.
2. Turn off all electric power to the appliance if service is to be performed.
3. Remove the front cover.
4. Turn gas shutoff valve to "off".
5. Install front cover.

⚠ DANGER

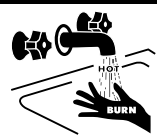

⚠ DANGER

Water temperature over 125 degrees F. can cause severe burns instantly, or death from scalds. Children, disabled, and elderly are at highest risk of being scalded. See instruction manual before setting temperature at water heater. Feel water before bathing or showering! Temperature limiting valves are available.

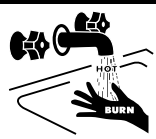

⚠ DANGER

MUNCHKIN 199VWH GAS VALVE

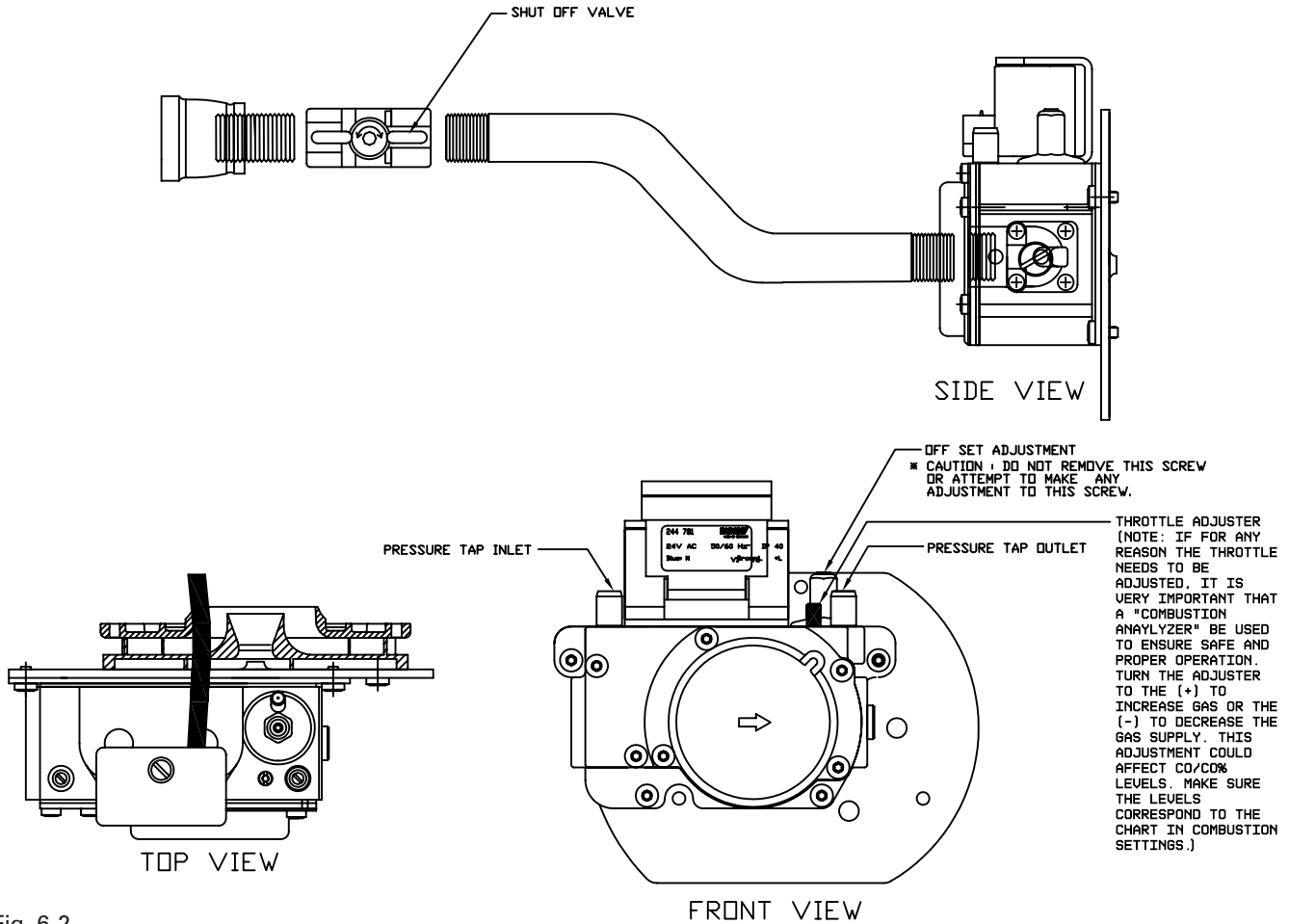

Fig. 6-2

MUNCHKIN 399VWH GAS VALVE

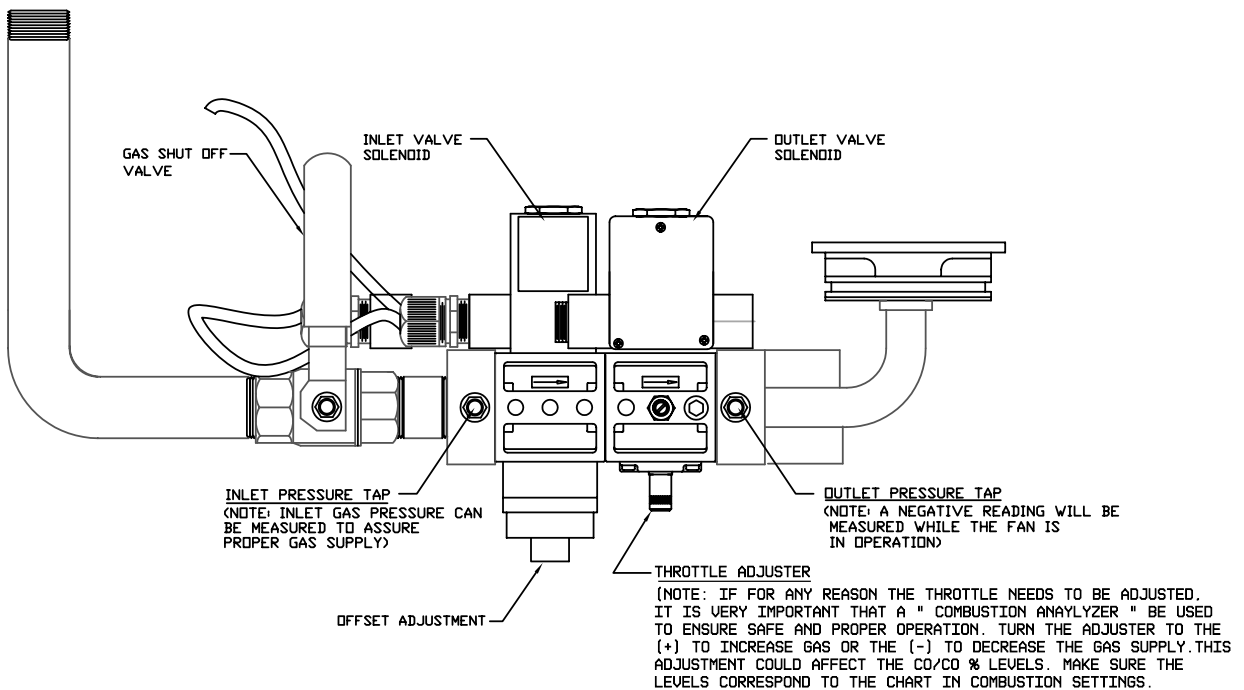

Fig. 6-3

PART 7. TROUBLESHOOTING

A. MUNCHKIN ERROR CODE

An error code may occur in the installation of the Munchkin VWH. This condition may lead to a lock out condition of the controller, which will need to be manually reset through the S4/Reset button. These temporary codes will help the installer correct the problem before going into a lock out condition, which will require a manual reset.

B. BOILER ERROR

1. When an error condition occurs the controller will display an error code on the display module.
2. These error codes and several suggested corrective actions are included in Table 7.1.
3. In the case of E00, E13, and E14 this error, if uncorrected, will go into a fault condition as described in Paragraph C (Boiler Fault).

C. BOILER FAULT

1. When a fault condition occurs the controller will illuminate the red "fault" indication light and display a fault code in the format (Example: **F00**) on the display module.
2. Note the fault code and refer to Table 7.2 for an explanation of the fault code along with several suggestions for corrective actions.
3. Press the reset key to clear the fault and resume operation. Be sure to observe the operation of the unit to prevent a recurrence of the fault.

WARNING

When servicing or replacing any components of this boiler be certain that:

- The gas is off.
- All electrical power is disconnected

DANGER

When servicing or replacing that are in direct contact with the boiler water, be certain that:

- There is no pressure in the boiler. (Pull the release on the relief valve. Do not depend on the pressure gauge reading).
- The boiler water is not hot
- The electrical power is off

WARNING

Do not use this appliance if any part has been under water. Improper or dangerous operation may result. Contact a qualified service technician immediately to inspect the boiler and to repair or replace any part of the boiler which has been under water.

CAUTION

This appliance has wire function labels on all internal wiring. Observe the position of each wire before removing it. Wiring errors may cause improper and dangerous operation. Verify proper operation after servicing.

CAUTION

If overheating occurs or the gas supply fails to shut off, do not turn off electrical power to the circulating pump. This may aggravate the problem and increase the likelihood of boiler damage. Instead, shut off the gas supply to the boiler at the gas service valve.

Table 7-1: 925 Control Board Error Codes

Code	Description	Duration	Corrective Action
E00	High Limit Exceeded	50 Sec.	<ol style="list-style-type: none"> 1. Check circulation pump operation. 2. Assure that there is adequate flow through the boiler by accessing the status menu and assuring that there is less than a 50°F rise from the return thermister to the supply thermister. 3. Replace switch if faulty.
E13	Combustion Fan Speed Low. The boiler combustion air fan speed less than 70% of expected.	60 Sec.	<ol style="list-style-type: none"> 1. Check the combustion air fan wiring. 2. Replace the combustion air fan. 3. Replace the control board.
E14	Combustion Fan Speed High. The boiler combustion air fan speed is more than 130% of expected.	60 Sec.	<ol style="list-style-type: none"> 1. Check the combustion air fan wiring. 2. Replace the combustion air fan. 3. Replace the control board.
FLO	Flow Switch Open	Until Corrected	<ol style="list-style-type: none"> 1. Assure that high velocity pump is operational. 2. Check pump impeller. 3. Check flow switch and paddle wheel.
FLU	Blocked Vent Pressure Switch	Until Corrected	<ol style="list-style-type: none"> 1. Assure that the vent is not blocked 2. Check the switch operation by applying a jumper. (If the switch is not functioning properly, replace.)

Table 7-2: 925 Control Board FAULT Codes

Code	Description	Remedy
F00	High Limit Exceeded.	<ol style="list-style-type: none"> 1. Check circulation pump operation 2. Assure that there is adequate flow through the boiler by accessing the status menu and assuring that there is less than a 50°F rise from the return thermister to the supply thermister. 3. Check thermister reading on supply thermister. Replace switch if faulty.
F01	Vent Temperature Limit Exceeded.	<ol style="list-style-type: none"> 1. Push the red reset button on the switch. 2. Check the flue temperature during operation using a combustion analyzer. 3. Replace the switch if faulty.
F02	Interrupted or Shorted Supply (Outlet) Thermister.	<ol style="list-style-type: none"> 1. Check the electrical connection to the thermister on the outlet manifold. 2. Replace thermister if necessary.
F03	Interrupted or Shorted Return (Inlet) Thermister.	<ol style="list-style-type: none"> 1. Check the electrical connection to the thermister on the inlet manifold. 2. Replace thermister if necessary.
F05	Supply (Outlet) Temperature exceeds 230°F.	<ol style="list-style-type: none"> 1. Check circulation pump operation. 2. Assure that there is adequate flow through the boiler by accessing the status menu and assuring that there is less than a 50°F rise from the return thermister to the supply thermister.
F06	Return (Inlet) Temperature Exceeded 230°F.	<ol style="list-style-type: none"> 1. Check circulation pump operation. 2. Assure that there is adequate flow through the boiler by accessing the status menu and assuring that there is less than a 50°F rise from the return thermister to the supply thermister.
F09	No flame detected – The boiler will make three attempts at ignition before the control goes into this lockout condition.	<ol style="list-style-type: none"> 1. Watch the igniter through the observation window provided. 2. If there is no spark, check the spark electrode for the proper 1/4" gap. 3. Remove any corrosion from the spark electrode and flame rectifier probe. 4. If there is a spark but no flame, check the gas supply to the boiler. 5. If there is a flame, check the flame sensor. 6. Check any flue blockage or condensate blocks.
F10	Loss of Flame Signal – The boiler will relight 4 times before the control goes into this lockout condition.	<ol style="list-style-type: none"> 1. Monitor the gas pressure to the unit while in operation. 2. Assure that the flame is stable when lit. 3. Check to see if the green light on the display module is out while the boiler is running. 4. If the green light doesn't come on or goes off during operation check the flame signal on the status menu. 5. If the signal reads less than 1 microampere, clean the flame rectifier probe. 6. If the flame rectifier probe continues to read low, replace it.
F11	False Flame Signal – The boiler will lock out if it senses a flame signal when there should be none present.	<ol style="list-style-type: none"> 1. Turn the gas off to the unit at the service valve. 2. If the flame signal is still present replace the igniter. 3. If the flame signal is not present after turning off the gas supply, check the gas valve electrical connection. 4. If there is no power to the gas valve, remove the valve and check for obstruction in the valve seat or replace the gas valve. 5. Turn the gas on at the service valve after corrective action is taken.
F13	Combustion Fan Speed Low – The boiler will lock out if it senses that the fan speed is less than 70% of expected rate for more than 60 seconds.	<ol style="list-style-type: none"> 1. Check the combustion air fan wiring. 2. Replace the combustion air fan. 3. Replace the control board.
F14	Combustion Fan Speed High – The boiler will lock out if the fan speed is more than 130% of expected rate for more than 60 seconds.	<ol style="list-style-type: none"> 1. Check the combustion air fan wiring. 2. Replace the combustion air fan. 3. Replace the control board.
F18	Gas Valve Error	<ol style="list-style-type: none"> 1. Make sure the connector is correctly connected to the gas valve. 2. Check the electrical wiring from the valve to the control board. 3. Replace the low voltage wiring harness assembly. 4. Replace control board.
F30	Watchdog	Call factory for further assistance.
F31	Parameter Memory	Call factory for further assistance.
F32	Parameter Memory Write Error	Call factory for further assistance.
F33	Programming Error	Call factory for further assistance.

RESISTANCE TABLES

Boiler	Resistance (ohms)
32	32550
41	25340
50	19870
59	15700
68	12490
77	10000
86	8059
95	6535
104	5330
113	4372
122	3605
131	2989
140	2490
149	2084
158	1753
167	1481
176	1256
185	1070
194	915
203	786
212	667

PART 8. MAINTENANCE

A. MAINTENANCE PROCEDURES

Periodic maintenance should be performed once a year by a qualified service technician to assure that all the equipment is in safe efficient operation. The owner can make necessary arrangements with a qualified heating contractor for periodic maintenance of the heater. Installer must also inform the owner that the lack of proper care and maintenance of the heater may result in a hazardous condition. The installer should discuss the contents of the User's Information Manual with the owner.

B. ANNUAL MAINTENANCE

A trained and qualified service technician should perform the inspections listed below at least once a year.

- **Heater** – check the heater for dust or foreign materials, which may have been drawn in from the air intake of the heater. Simply blow out or wipe down with a dry rag.
- **Vent Termination** – check to remove any obstructions, such as leaves, bushes, or other sources which may interfere with the units ability to draw fresh air on the air intake or exhaust flue gas from the exhaust outlet.
- **Vent Piping** – make sure that all vent piping is in good condition. Check Joints for possible leaks.
- **Condensate** – check the Condensate trap by simply starting the unit and observing the flow of Condensate which should not be restricted in any fashion. (See instructions below.)
- **Heat Exchanger** – in the unlikely event the heater flue passage is becoming blocked, service must be performed only by an authorized Heat Transfer Products Representative or Certified Installing Contractor. (See coil cleaning instructions Section D)
- **Burner** – check burner for deterioration. If deterioration is observed, replace burner.
- **System Water / Pressure** – check pressure regulator and system pressure. Check system for air which will create noise. Open air vents or purge system to bleed air then close once air is fully purged from the system.
- **Water Piping** – check for and repair any leaks.
- **Gas Piping** – check for and repair any leaks.

C. CONDENSATE CLEANING INSTRUCTIONS

1. Turn down the temperature setpoint **dd** so the Munchkin will not cycle and then follow the steps below.
 - a. Close gas valve
 - b. Disconnect the condensate hose from the **outside** connection (**not from the Munchkin**) so flow can be observed.
 - c. Block the air flow in the exhaust by temporarily plugging the exhaust from the outside vent.
 - d. Turn up the temperature set point **dd** so the Munchkin VWH will begin to cycle. This will cause the fan to run at 100% which will then blow out any sediment that has accumulated in the condensate line. This process should only take a few minutes.
 - e. The unit should now be ready to re-start.
2. Before re-starting the Munchkin follow the steps below:
 - a. Reconnect the Molex connection and un-block the vent (**IMPORTANT: MAKE SURE EXHAUST VENT IS NO LONGER BLOCKED!**)
 - b. Open the gas valve.
 - c. Hit System Reset and increase the temperature to assure that the VWH will operate.
 - d. Observe the boiler function to make sure you see a condensate flow.
 - e. If you do not observe a condensate flow, repeat the above procedure.
3. If the problem is not corrected at this point, it is possible you have a material deposit problem,

in which case, a qualified plumber will need to be contacted to follow the Coil Cleaning Instructions (Section D) included in this section to dissolve deposit and clean condensate line.

! DANGER

IT IS EXTREMELY IMPORTANT TO MAKE SURE THE EXHAUST VENT IS NO LONGER BLOCKED. FAILURE TO DO SO MAY RESULT IN PERSONAL INJURY OR DEATH.

D. COMBUSTION CHAMBER COIL CLEANING INSTRUCTIONS*

*Before beginning this procedure, you must have on hand the following items:

- a nylon, stainless or brass brush (not steel)
- "Rydlyme" (recommended for best results) (available on line www.rydlyme.com) or "CLR" (available at most hardware stores)

1. Shut down the Munchkin by using the following steps:
 - a. Close the gas valve, shut down the unit and wait for the unit to be cool to the touch
 - b. Disconnect the condensate hose from the **outside** connection, (**not from the Munchkin side**), so the flow can be observed.
 - c. Remove screws and loosen bracket holding gas valve in place.
 - d. Pull connector to the venturi by sliding gas valve to left, remembering to disconnect both Molex connectors.
 - e. Remove the (6) 10MM nuts from the burner plate assembly to access the coils.
 - f. Pull the entire burner plate assembly towards you, while removing or pushing aside any wiring to allow the removal of the assembly.
2. Using a spray bottle filled with the recommended product "RYDLYME" or "CLR", spray liberally on the coils, making sure the solution penetrates and funnels down through the condensate hose. If the condensate hose is blocked, let the chemical penetrate for at least 15 minutes or until it drains.
3. Use the nylon, stainless or brass brush (do not use steel) and scrub coils to remove any buildup, then vacuum the debris from the coils.
4. Spray the coils with clear water, making sure to confine the spray to the area being cleaned (Try to avoid getting the back ceramic wall of the unit wet). Flush the combustion chamber with fresh water. At this point, the Munchkin should be ready to power back up.

Before powering up the Munchkin follow the steps below

- a. Re-install the burner assembly
- b. Replace the (6) 10MM nuts to the burner plate
- c. Re-connect the Molex connectors
- d. Re-connect gas valve, air-gas mixer and replace bracket. (**IMPORTANT: CHECK FOR GAS LEAKS**)
- e. Re-set thermostats (**IMPORTANT: MAKE SURE EXHAUST VENT IS NO LONGER BLOCKED!**)
- f. Turn the Munchkin back on** and observe condensate flow.
- g. Re-connect the condensate hose to the outside connection.

! DANGER

IT IS EXTREMELY IMPORTANT THAT YOU CHECK FOR LEAKS WHEN RECONNECTING THE GAS VALVE AND MAKING SURE THE EXHAUST VENT IS NO LONGER BLOCKED. FAILURE TO DO SO MAY RESULT IN SEVERE PERSONAL INJURY OR DEATH.

****NOTE: When firing up the boiler for the first few times you may experience some fluttering of the gas burner that may result in a flame lockout. This is normal and will require you to re-cycle the unit until this clears up. This is caused by water still present in the combustion chamber.**

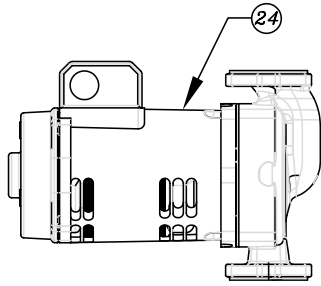

CIRCULATOR PUMP

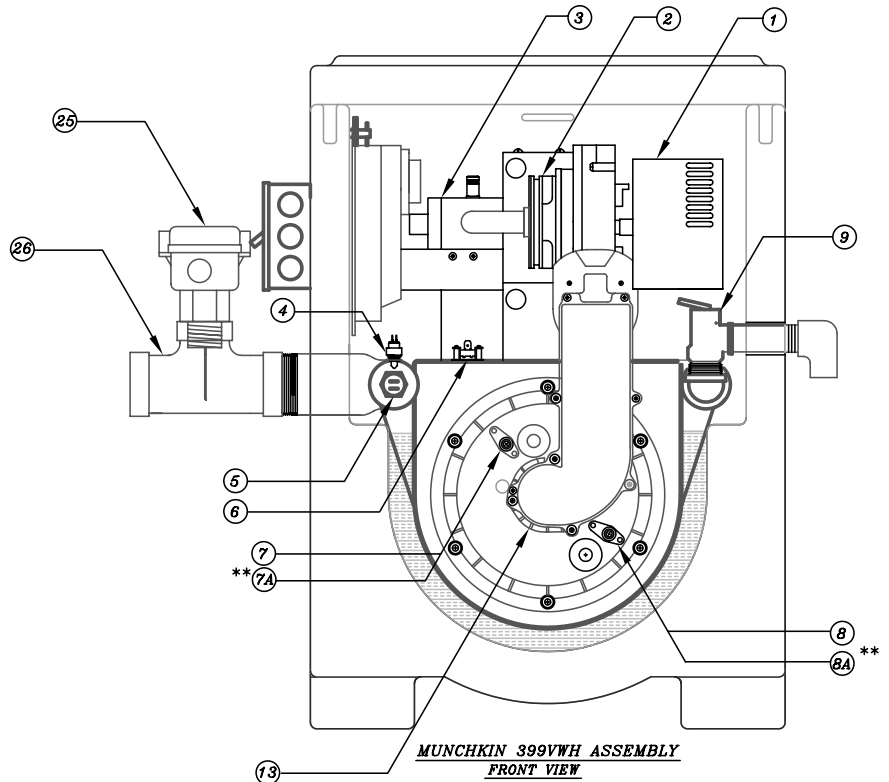

MUNCHKIN 399VWH ASSEMBLY
FRONT VIEW

**** THE LOCATION OF THE HOT SURFACE IGNITOR AND FLAME RECTIFICATION PROBE IS REVERSED FOR ALL HA MODELS**

COMPONENTS ASSEMBLY
399VWH REPLACEMENT PARTS

- | | |
|--|----------------|
| 1. BLOWER MOTOR (INCLUDES GASKET) | 7250P-518 |
| 2. AIR GAS MIXER | 7250P-545 |
| 3. AIR/GAS VALVE ASSEMBLY | 7250P-540 |
| 4. THERMISTOR INLET/OUTLET | 7250P-423 |
| 5. ECO HIGH LIMIT | 7250P-019 |
| 6. THERMODISC FLUE ECO - 210° F | 7250P-089 |
| 7. SPARK ELECTRODE (INCLUDES GASKET) | 7250P-058 |
| ** 7A. FLAME RECTIFICATION PROBE
(THIS LOCATION FOR HA MODELS ONLY) | 7250P-049 |
| 8. FLAME RECTIFICATION PROBE
(INCLUDES GASKET) | 7250P-049 |
| ** 8A. HOT SURFACE IGNITOR
(THIS LOCATION FOR HA MODELS ONLY) | 7250P-279 |
| 9. RELIEF VALVE | 7250P-576 |
| 10. MAIN VALVE SOLENOID | 7250P-553 |
| 11. FIRST VALVE SOLENOID | 7250P-552 |
| 12. GAS BALL VALVE | 7250P-544 |
| 13. BURNER (INCLUDES GASKET) | 7250P-502 |
| 14. MOLDED CERAMIC REFRACTORY | 7250P-161 |
| 15. CONTROL DISPLAY BOARD
(INCLUDES RIBBON CABLE) | 7250P-332 |
| 16. 925 CONTROL BOARD
(INCLUDES TRANSFORMER) | 7250P-317 |
| 17. WIRING HARNESS LOW VOLTAGE
(10 PIN/20 PIN) | 7250P-599 |
| 18. WIRING HARNESS
(9 PIN, 120 VOLT) | 7250P-602 |
| | 7250P-601 (HA) |
| 19. WIRING HARNESS
(5 PIN, 120 VOLT) | 7250P-390 |
| 20. SPARK CABLE
(NOT REQUIRED ON HA MODELS) | 7250P-392 |
| 21. CONTROL BOARD FUSE
(110 VOLT, 6.3 AMPS) | 7250P-378 |
| 22. CERAMIC TARGET WALL | 7250P-160 |
| 23. GAS VALVE RELAY (CONTACT FACTORY TO ORDER) | |
| 24. CIRCULATOR PUMP | 7250P-592 |
| 25. FLOW SWITCH | 7250P-612 |
| 26. BRASS TEE | 7250P-588 |
| 27. BLOCKED VENT PRESSURE SWITCH | 7250P-150 |

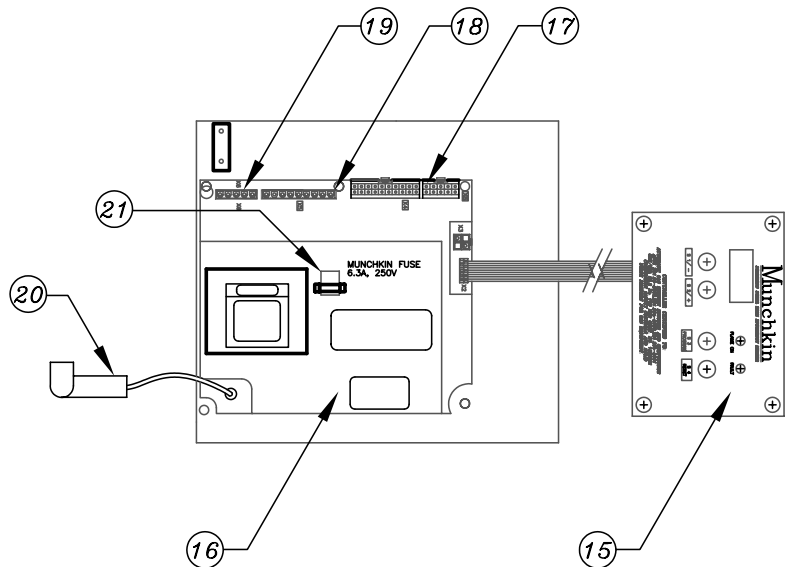

925 CONTROL BOARD ASSEMBLY

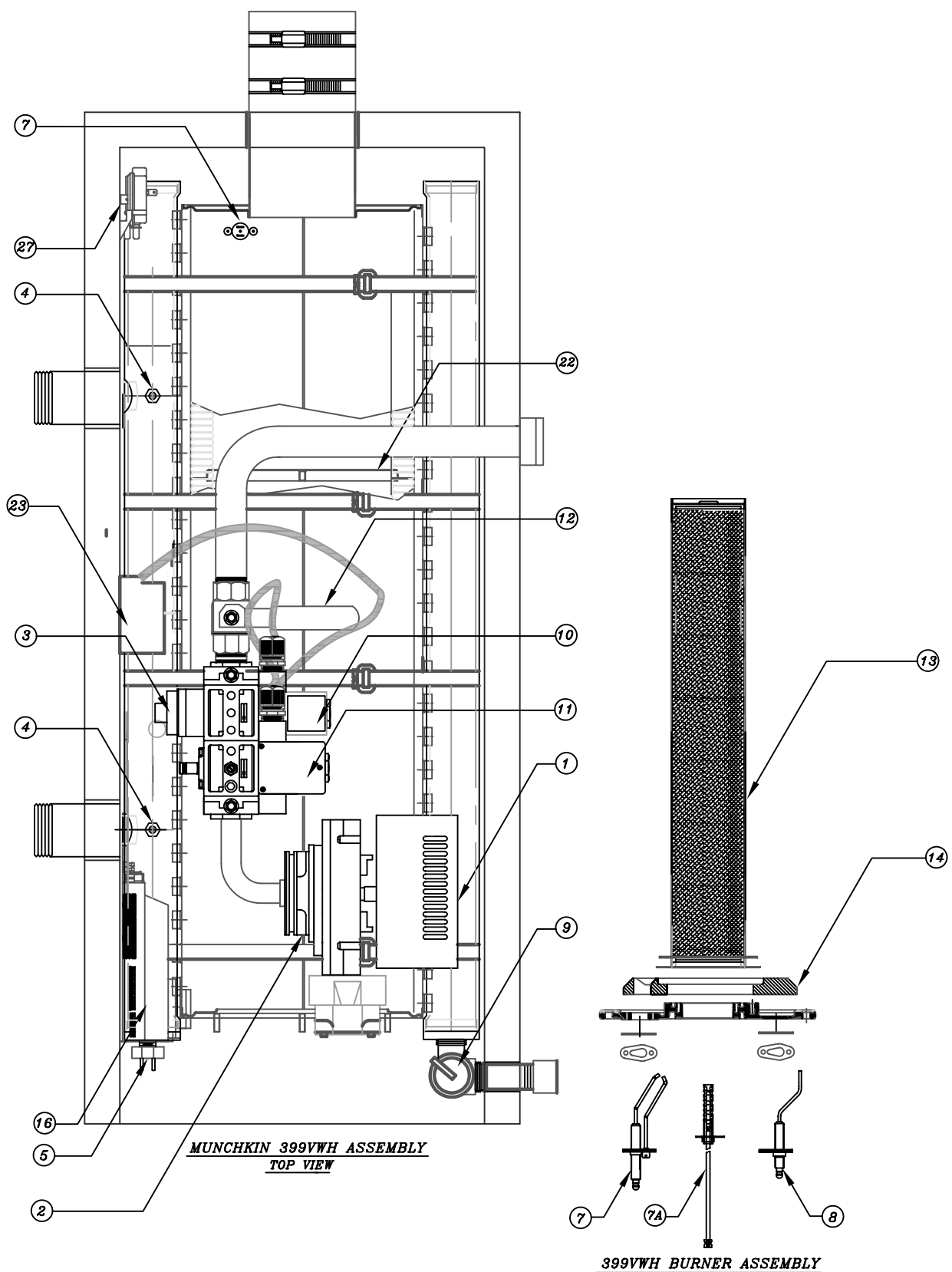

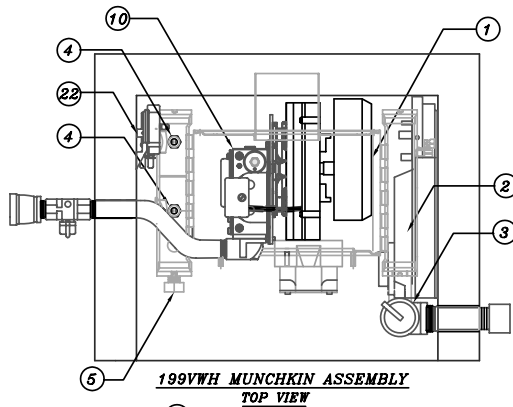

**199VWH MUNCHKIN ASSEMBLY
TOP VIEW**

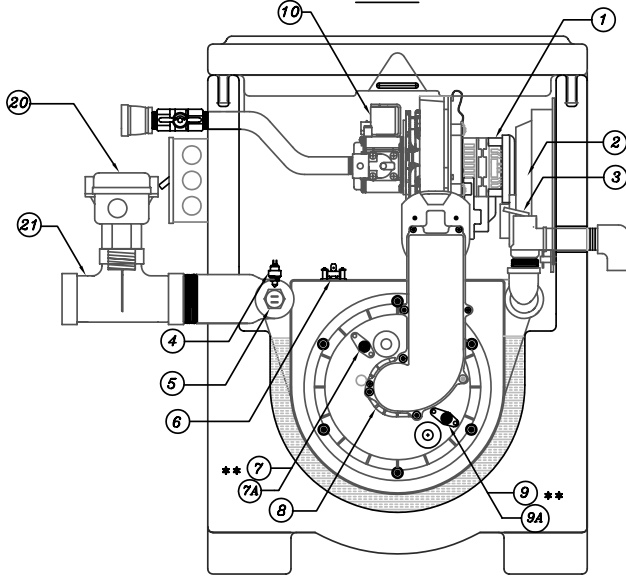

**199VWH MUNCHKIN ASSEMBLY
FRONT VIEW**

**** THE LOCATION OF THE HOT SURFACE IGNITOR AND FLAME RECTIFICATION PROBE IS REVERSED FOR ALL HA MODELS**

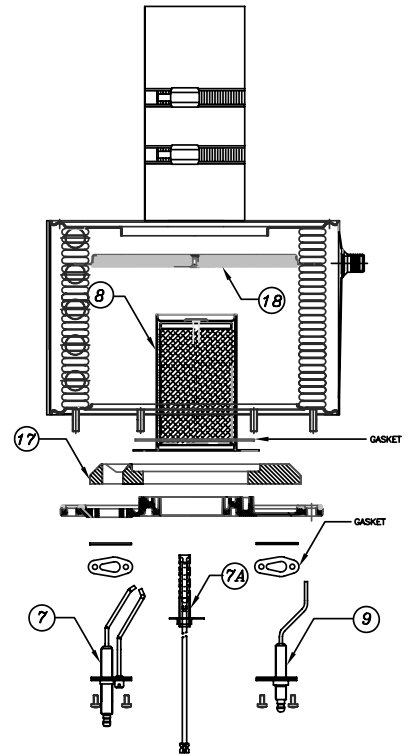

199VWH BURNER ASSEMBLY

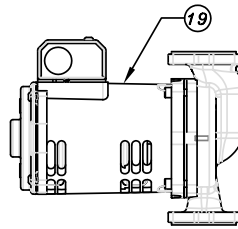

CIRCULATOR PUMP

**COMPONENTS ASSEMBLY
199VWH REPLACEMENT PARTS**

- | | |
|--|----------------|
| 1. BLOWER MOTOR
(INCLUDES GASKET) | 7250P-087 |
| * 2. 925 CONTROL BOARD
(INCLUDES TRANSFORMER) | 7250P-317* |
| 3. RELIEF VALVE | 7250P-219 |
| 4. THERMISTOR INLET/OUTLET | 7250P-423 |
| 5. ECO HIGH LIMIT | 7250P-019 |
| 6. THERMODISC FLUE ECO - 210° F | 7250P-089 |
| 7. SPARK ELECTRODE
(INCLUDES GASKET) | 7250P-058 |
| ** 7A. FLAME RECTIFICATION PROBE
(THIS LOCATION FOR HA MODELS ONLY) | 7250P-049 |
| 8. BURNER
(INCLUDES GASKET) | 7250P-250 |
| 9. FLAME RECTIFICATION PROBE
(INCLUDES GASKET) | 7250P-049 |
| ** 9A. HOT SURFACE IGNITOR
(THIS LOCATION FOR HA MODELS ONLY) | 7250P-279 |
| 10. GAS VALVE (DUNGS) | 7250P-452 |
| 11. CONTROL DISPLAY BOARD
(INCLUDES RIBBON CABLE) | 7250P-332 |
| 12. CONTROL BOARD FUSE
(110 VOLT, 6.3 AMPS) | 7250P-378 |
| 13. WIRING HARNESS LOW VOLTAGE
(10 PIN/20 PIN) | 7250P-600 |
| 14. WIRING HARNESS
(9 PIN, 120 VOLT) | 7250P-602 |
| | 7250P-601 (HA) |
| 15. WIRING HARNESS
(5 PIN, 120 VOLT) | 7250P-386 |
| 16. SPARK CABLE
(NOT REQUIRED ON HA MODELS) | 7250P-392 |
| 17. MOLDED CERAMIC REFRACTORY | 7250P-161 |
| 18. CERAMIC TARGET WALL | 7250P-160 |
| 19. CIRCULATOR PUMP | 7250P-591 |
| 20. FLOW SWITCH | 7250P-590 |
| 21. BRASS TEE | 7250P-589 |
| 22. BLOCKED VENT PRESSURE SWITCH | 7250P-150 |

* PLEASE SPECIFY MODEL AND SERIAL # OF UNIT WHEN ORDERING 925 CONTROL BOARDS.

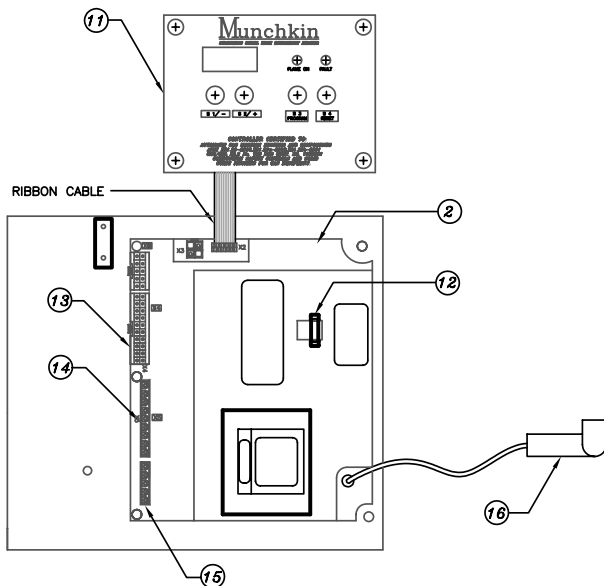

925 CONTROL BOARD ASSEMBLY

